



KVU OSLO- NAVET

Tunnelboremaskiner (TBM)

Ferdigstilt: 3. september 2014

Prosjekt: KVU Oslo-Navet

Forfattere: Håkon Bratlien, Amberg Engineering

Prosjektkontakt: Terje Grytbakk, KVU-staben

Vedlegg til: Vedlegg 8, teknisk-økonomisk plan

Sammendrag:

Dette er en kartlegging av hvilke boremetoder som kan egne seg for grunnen i Oslo-området.

Table of content

Table of content.....	2
Introduction	4
Scope of work	4
Description of the project.....	5
Tunnelling in Oslo – Description of a fictitious section	6
Tunnel construction using TBM	8
Tunneling in hard rocks.....	8
Steel structure and wear protection of the cutter head	9
Cutting tools and mucking system of a cutter head.....	12
Mitigation measures to limit water inflow.....	13
Tunnelling in soft soils.....	16
TBM technology for soft soils.....	17
Hydroshield.....	19
Earth Pressure Balance Shield (EPB)	21
Important features for the TBM concept to cope with hard rock are	23
Important features for the TBM concept to cope with soft soil are	24
Transition zones	25
Mixed face conditions	26
Presence of boulders	26
TBM excavation through soft clay filled “valleys”	28
Multi-Mode TBMs, the solution for changing geological conditions.....	32
Comparison of a Multi-Mode Hydro shield and EPB.....	34
Handling clay conditions	35
Plasticity (in relation to stickiness).....	35
Special design features.....	37
Site access and rig area	38
Environmental overview	40
Summary/comparison between TBM and drill & blast.....	40
Recycling of the muck material.....	41
Conclusions and recommendations	42
References	43
Appendix, Reference projects	44

Gotthard Base Tunnel – Hard rock project	44
Vereina Tunnel – Hard rock project.....	45
Follobanen Oslo-Ski – Hard rock project.....	46
Hallandsåsen tunnel – Hard rock project	47
Berlin Metro U5 – Soft soil project.....	48
Zurich Airport Sky metro – Soft soil project	49
Metro Sabadell – Soft soil project.....	50
Metro Delhi – Soft soil project.....	51
Grauholztunnel – Multi mode TBM	52
Weinbergtunnel – Multi mode TBM	53
Zimmerbergtunnel – Multi mode TBM.....	54
Finnetunnel – Multi mode TBM.....	55

Introduction

Scope of work

In most large cities in the world, the only solution to deal with increased traffic from the suburb areas of the city during rush hours, is to place public transportation lines underground as much as possible. In Oslo, one of the most important hubs of Scandinavia, this problem is evident.

Rock surface embossed by the glaciers underground are often traversed by “valleys” filled with moraine and silt clay. New infrastructure tunnels have to be placed quite deep to be excavated only in hard rock. That would lead to very long access distances, lower flexibility to geometric alignment and would greatly reduce the comfort standard.

For infrastructure projects outside of the city centres, the passage through those “valleys” filled with soil is normally realized using an open pit construction (excavation of the pit, construction of a concrete tunnel, backfill of the pit), to which the tunnel sections excavated by drill & blast are connected. In city and city centres, this method is not the most recommended, as it often implies the demolition of (historical) buildings, large noise/dust disturbances and a precarious traffic situation during the construction as it would be deviated.

The scope of the following study is to show the most appropriate underground construction method based on a representative fictive section for a new transportation line in the urban underground of Oslo, which requires interventions from the surface only in station areas.

Description of the project

The diagrams below shows the project limits of Oslo Navet. The connection of the cities around Oslo to the city center will improve distinctly by projects like Follobanen that will significantly reduce travel time of commuting traffic.

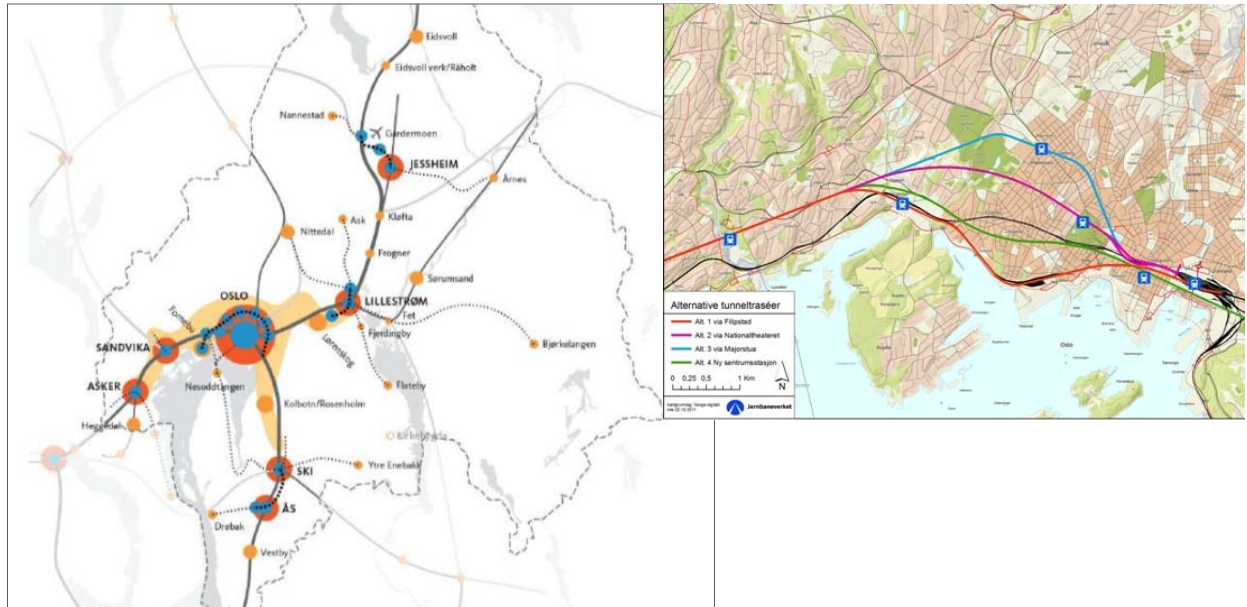

Figure 1: Project area of Oslo Navet and alignment study to cross the center of Oslo

Tunnelling in Oslo – Description of a fictitious section

The geological conditions in the area of the study are assumed mainly consisting of a strong bedrock mostly composed of shale, limestone, modular limestone and alum shale. The sediments often consist of layers of moraine overlaid by layers of soft to very soft clays and silts. The transition zones between competent bedrock and sediments include weathered rock. The presence of cobbles and boulders in this zone is more likely.

Groundwater levels are often only a few meters below surface. This makes it necessary to grout the bedrock ahead of excavation to reduce water inflow below the accepted limit.

The surface of the bedrock is heterogeneous and comprises hills and valleys as a result to glacial weathering and folding.

It is assumed that the vertical alignment of the tunnel crown will be covered by a sufficient overburden of ground to ensure safe working conditions.

The common tunnel diameters are:

- Metro, single track tunnel 6,0 – 7,0 m
- Metro, double track tunnel and high speed trains, single track tunnel 9,5 – 10,5 m
- High speed trains, double track tunnel 12,0 – 13,0 m

The next figure gives a simplified representation of a tunnel in bedrock with a fictitious crossing of a valley filled with soil to identify the main challenges for this kind of geology. These are described in the following paragraphs and techniques, as well as measures to mitigate them, are presented.

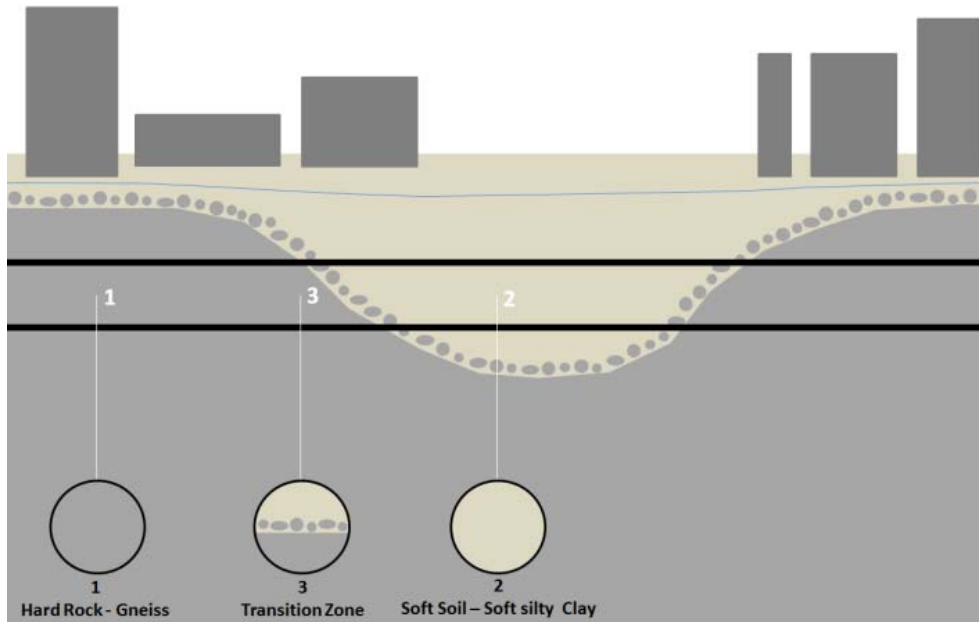

Figure 2: Simplified geological situation in Oslo / transition zones

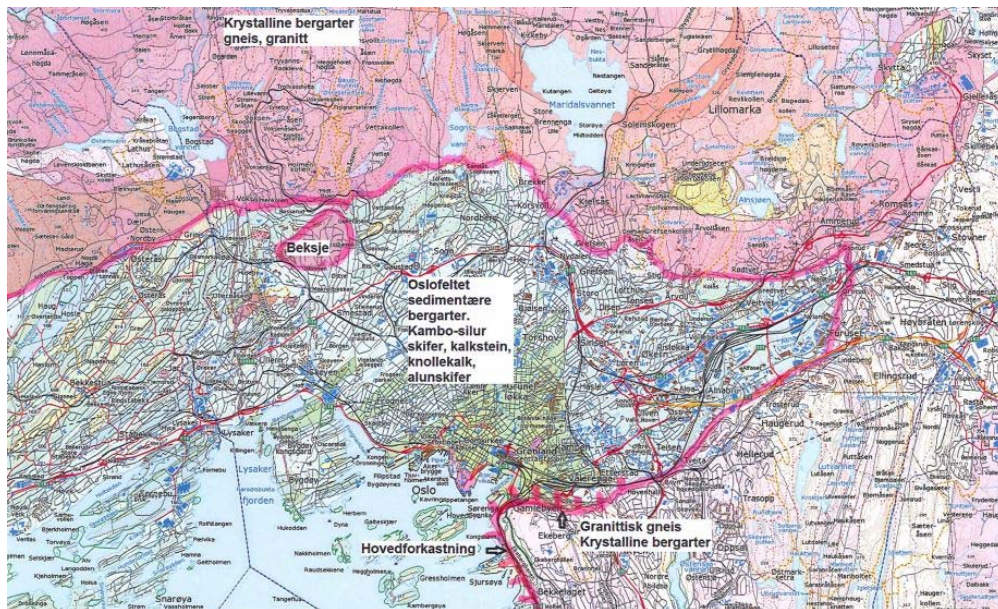

Figure 3: Simplified overview of the geological situation in Oslo area

Tunnel construction using TBM

A tunnel boring machine is used to excavate tunnels in different types of rocks and soil. The size of these machines can be adapted to specific project requirements. The biggest TBM build until now is 19,25m in diameter and runs in Saint Petersburg in Russia. The machines (TBM's) are build up to optimize the drilling advances depending on which soil and rock type it will run through in each project. The biggest tunnel boring machine build to run in hard rock are 14,4m in diameter.

To set up TBM requirements, it is necessary to do a thorough investigation and assessment of soil and rock conditions. These requirements must be setup by experts with experience from different projects. When TBM is configured to the geological picture of the project, it will run in a very efficient way. In a very basic overview, we can divide the tunnel boring machines in two different categories; soft soil and hard rock. There are big difference between the conventional drill & blast method and tunneling by TBM's.

In the back of all TBM's, there are a backup system. This system handles the muck from tunnel face and backwards in the machine. In this part of the machine, there are a control room, ventilation and equipment suitable for different support systems.

Tunnel boring machines are very suitable for tunneling in urban areas. If the TBM is adapted according to geological investigations and required information and risk assessments, it will run with very low risk of making problems to the terrain surface and possible change in the stability of the ground.

Tunneling in hard rocks

The hard rock section is assumed to consist of a hard and abrasive rock which will challenge the steel structure of the TBM, especially the cutter head.

⇒ High rock strength

Additionally, as the tunnel is expected to be build under the groundwater level water inflows are possible and have to be limited to the acceptable amount fixed by the client.

⇒ Water inflow

Those issues are summarized in the figure below. The necessary measures to reduce or mitigate the risks are described in the following paragraphs.

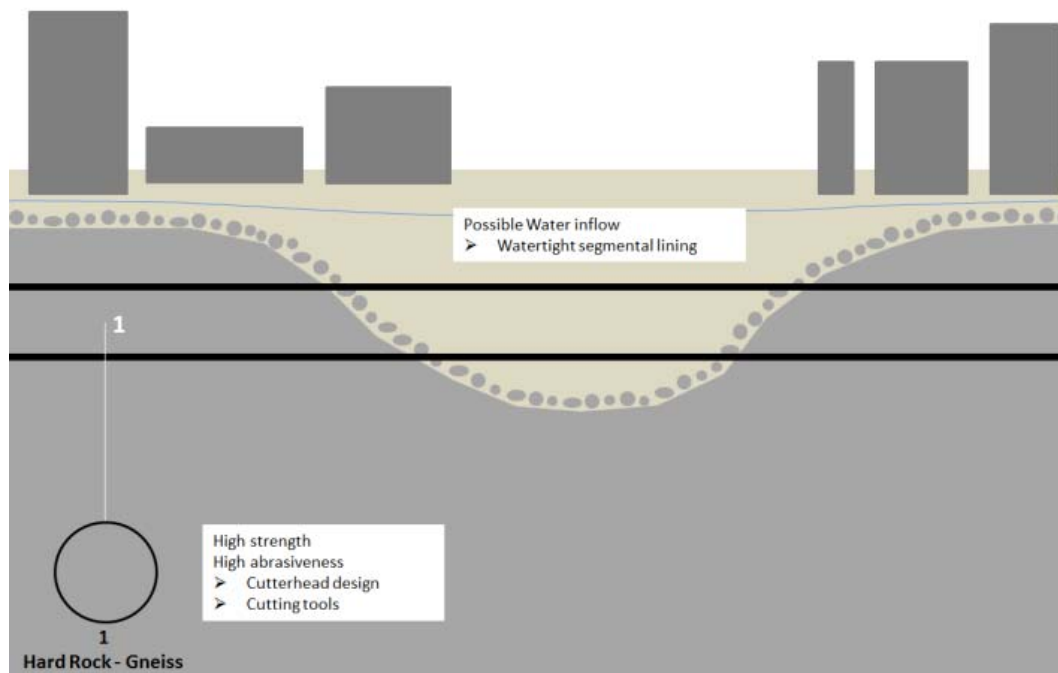

Figure 4: Challenges identified in the hard rock sections

Steel structure and wear protection of the cutter head

To cope with the hard rock conditions, the cutter head should consist of a heavy steel fabrication. The steel structure has to be strong enough to resist to all dynamic loads, like strokes and vibrations resulting from rock breaking and cracking processes of the cutter head on the tunnel face.

The pictures below (left) show the heavy and bulky cutter head used at Gotthard Base Tunnel to excavate hard rock like granite and gneiss. The cutter head is nearly 2 m thick and characterized by a very closed geometry. The picture on the right shows the cutting wheel of a Hydroshield TBM used for the excavation of soft soils for the project Botlekspoortunnel in Holland. In that case, the cutting wheel is quite tinny and acts like a scraper. The most important aspect is here an easy material flow of excavated soil in the excavation chamber. For comparison, the weight of both structures is given.

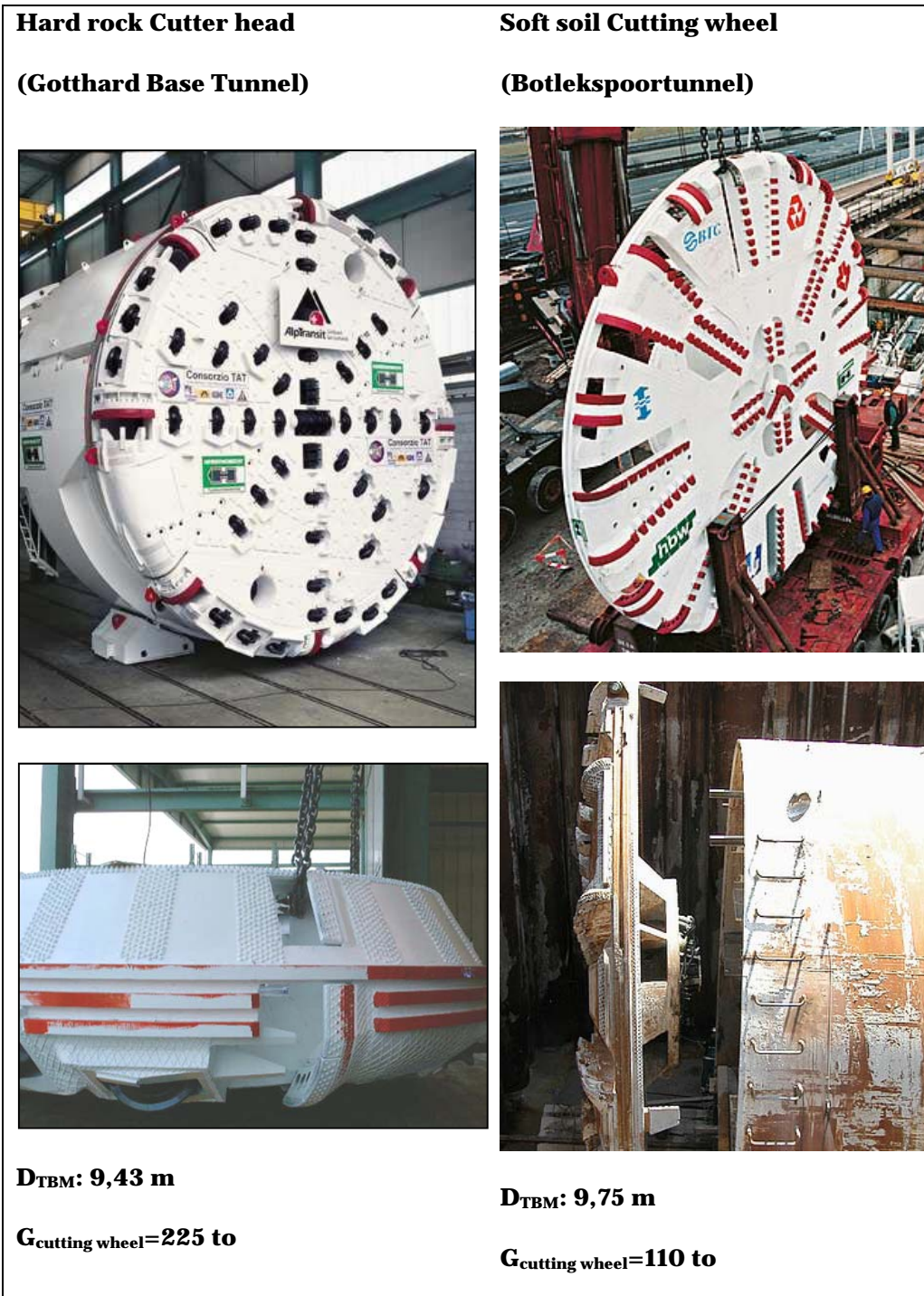

Figure 5: Comparison of hard rock cutter head and soft soil cutting wheel

Wear protection will be of paramount importance to deal with in abrasive rock conditions. TBM cutter head in similar conditions are extensively covered with

Hardox plates to prevent excessive wear on the steel structure. The wear protection would ideally consist of:

- ⇒ Wear plates to protect the cutter head face (red arrow)
- ⇒ Wedges to protect the cutters (white arrow)
- ⇒ Wear protection at cutter head periphery (light blue arrow)
- ⇒ Grills bars to protect the cutter head (dark blue arrow)
- ⇒ Grill bars to protect the scrapers from big blocks and control maximum block size to enter the cutter head (green arrow)

The picture on the right shows the wear protection used at the Hallandsåsen Railway project in Sweden.

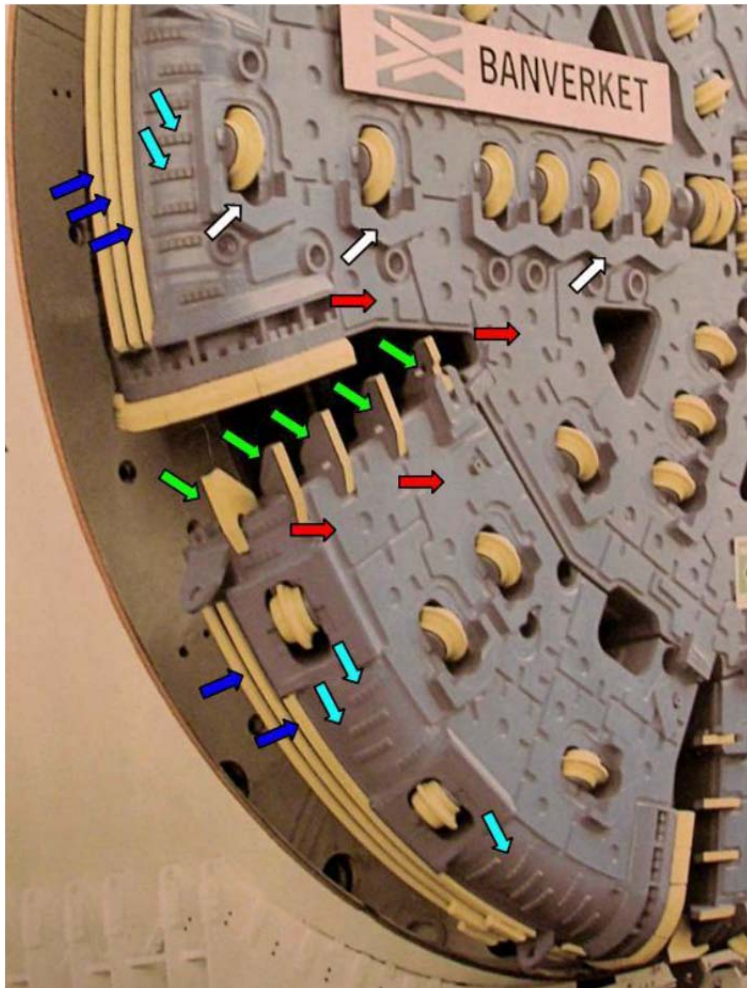

Figure 6: Example of wear protection on the cutter head of the Hallandsåsen TBM

Cutting tools and mucking system of a cutter head

The cutter head will be equipped with hard rock cutting tools such as twin disc cutters, single disc cutters and gauge cutters with at least 17" diameter discs or higher designed for hard rock conditions. A relatively small spacing (from min. 70 mm (-17") to 100 mm (-19")) would be necessary to ensure an optimal chipping of the rock. The choice of the right cutter ring material is of paramount importance for an efficient rock excavation.

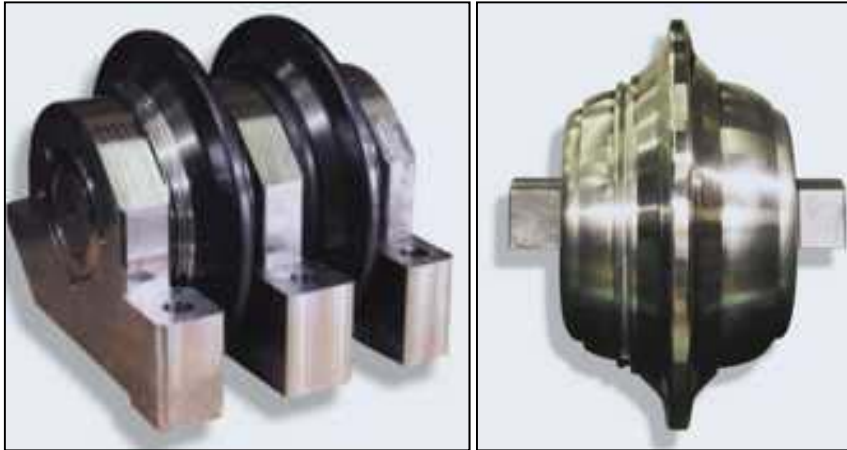

Figure 7: Hard rock cutting tools – the disc cutters

The excavated rock chips fall down in front of the cutter head to be picked up by the bucket lips and conveyed through muck chutes to the muck ring. Finally the muck is transported on the conveyor belt from the center of the cutter head to the surface. All features of the mucking process have to be optimized in size and shape in order to ensure high advance rates and low wear also in the gauge area.

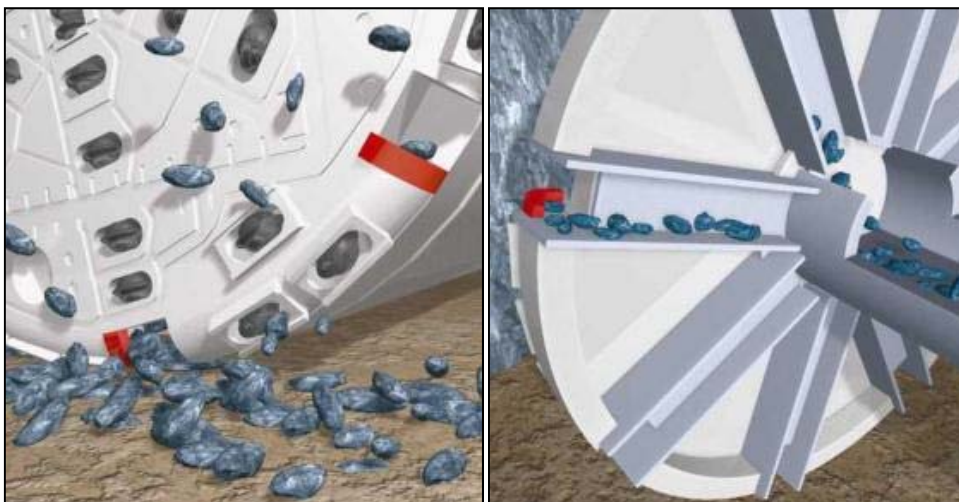

Figure 8: Mucking principles – the use of bucket lips

The use of muck material depends on several parameters, amongst them the rock quality and chip size.

Mitigation measures to limit water inflow

The tunnel is expected to be built below groundwater level. Experience from other tunneling projects in Norway and other Scandinavian countries shows that a limitation of the groundwater inflow into the tunnel to a level of a few liters per 100 m tunnel and minute, avoids settlements in the soft soil layer covering the bedrock.

When using conventional tunneling methods (drill & blast) in Norway, the water inflow is successfully reduced to the allowed limitations by following the systematical pre-excitation grouting process.

TBM excavation method offers a combined solution to comply with the restrictions of groundwater inflow:

- ⇒ **Shielded TBM with bulkhead** to seal any water inflow out of the rock above accepted limitation,
- ⇒ **Pre-excitation grouting** equipment in order to reduce the permeability of the rock and consequently limit the groundwater inflow in water bearing zones.
- ⇒ Use of **watertight segmental lining**, equipped with gasket and capable to withstand the current groundwater pressure. The annular gap of about 15 cm between the excavated tunnel and the outside of the watertight segmental lining will be filled continuously with mortar while excavation is going on. This aims to ensure the best possible bedding of the segment ring and avoid water circulation along the tunnel lining.

If the allowed maximum inflow rate reached, the TBM will be stopped and sealed (muck conveyor withdrawn). After rock is pre-grouted and inflow rate falls below allowed limitation, TBM can restart excavation. The figures below and on the next page show the combined TBM solution in case of groundwater pressure.

The following TBM types are designed for different requirements in hard rock tunneling:

- **Open Gripper TBMs** have the advantage to adapt rock safety measures to the quality of the surrounding rock and are therefore most economical in good rock mass conditions. To keep water inflow below limitation, pre-grouting measures would be similar to the one used for Drill & Blast method. During pre-grouting, excavation has to stop, what annihilates all advantages of an open gripper TBM.
- **Shielded TBMs** with segmental lining equipped for pre-grouting are common in soft rock to increase safety level during excavation. The shield protects the tunnel crew against rock fall causing many accidents when

using Drill & Blast or Gripper TBMs. Furthermore excavating performance of a shielded TBM is 2 to 3 times higher than Drill & Blast.

- If **shielded TBM** (also equipped for pre-grouting) are combined with watertight lining where water inflows, it is possible to reduce the zone between tunnel face and tail skin (~10 m). This enables shielded TBMs to cross through normally fractured rock conditions without reaching the water inflow limitations.
- In water bearing rock section (heavy fractured rock) where inflow rates expected to exceed the allowed limitations, a TBM basically equipped for pre-grouting will additionally be equipped to set up a counter pressure on the tunnel face with use of a bulkhead and bentonite circuit.

This avoids any water inflow into the tunnel. After pre-grouting the surrounding rock, excavation will restart.

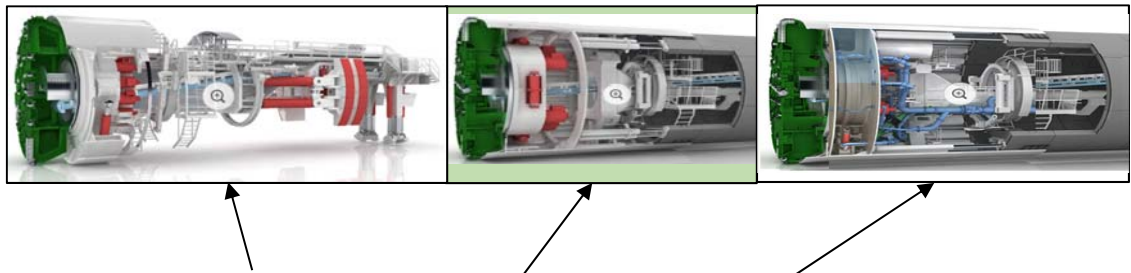

Figure 9: Open Gripper TBM, open shielded TBM, shielded TBM with Bulkhead and Bentonite circuit (Herrenknecht)

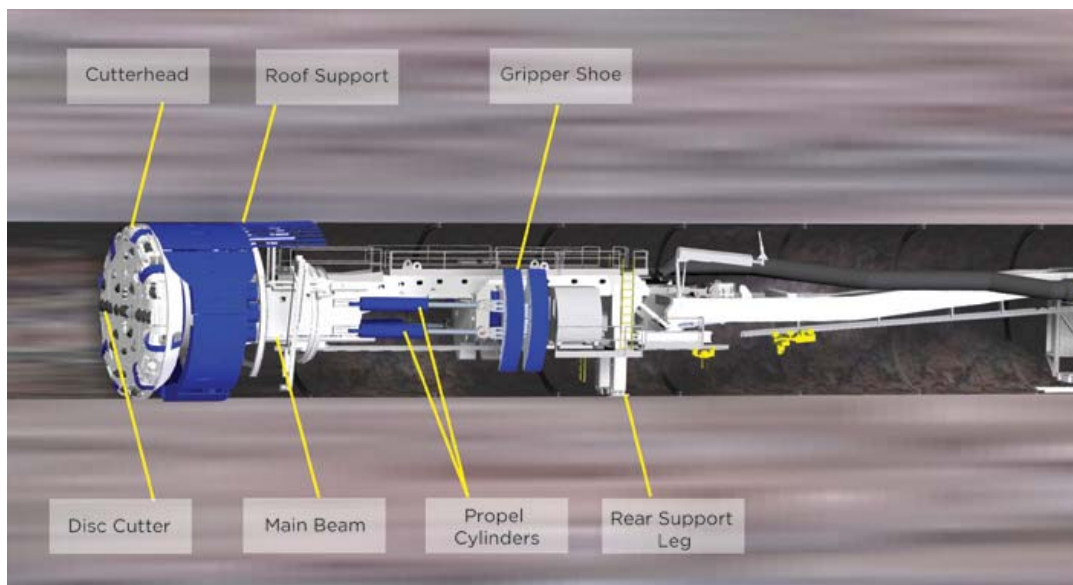

Figure 10: Main Beam Machine TBM (Robbins)

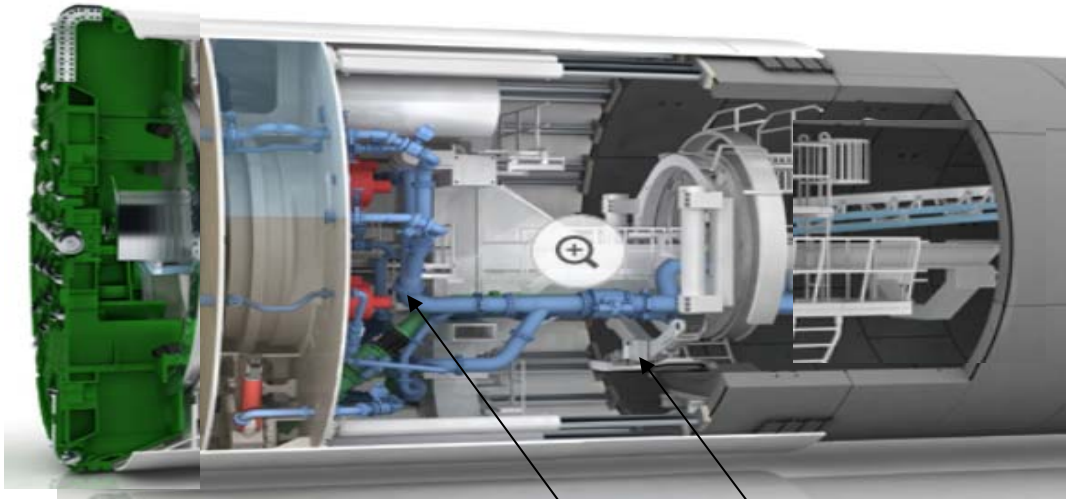

Figure 11: Shielded TBM with Bulkhead and Bentonite circuit (Herrenknecht)

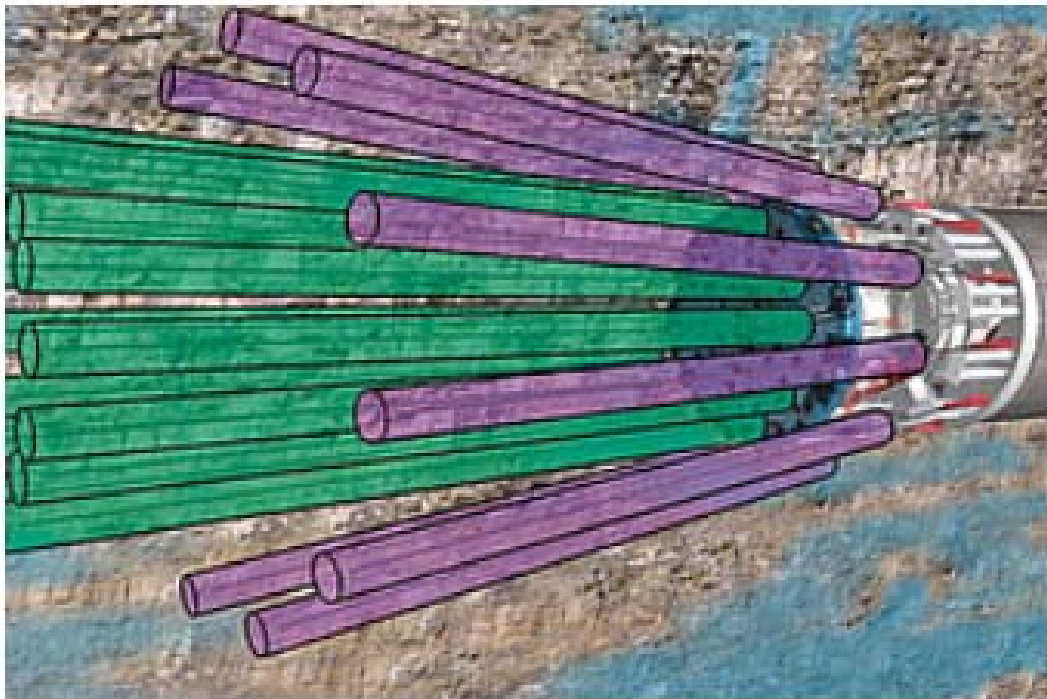

Figure 12: Reaching area of installed pre grouting equipment

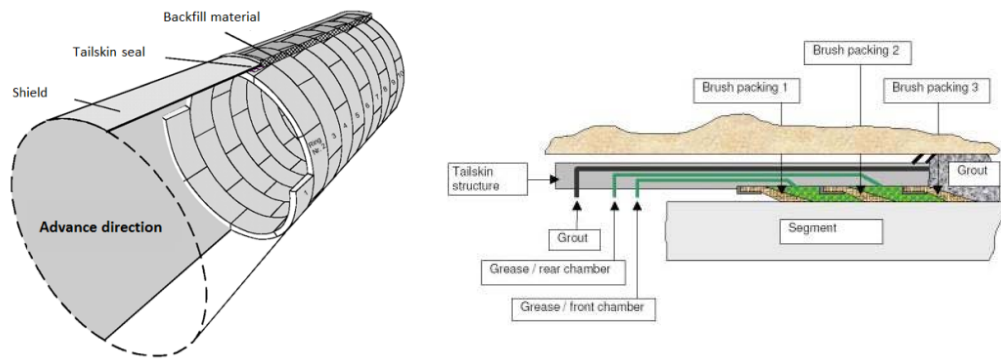

Figure 13: Segmental lining and backfill grouting / tunnel in soft soils

Tunnelling in soft soils

The soft soil sections is expected to consist of soft to very soft clay and silt-clay with a high fine grain content and an expected low plasticity (due to high water content).

In these cases, and as a rule of thumb the overburden should exceed 1,5 times the diameter of the tunnel.

Tunnel excavation in urban areas will possibly impact a large number of existing buildings and infrastructure utilities. In soft soil tunneling, settlements are controlled by adapting support pressure on the tunnel face and circumference area of the shield until segment lining is backfilled.

Accordingly to this topic, the control of the settlements will be one of the main challenges in the project, even if the tunneling method is done by conventional methods or TBM.

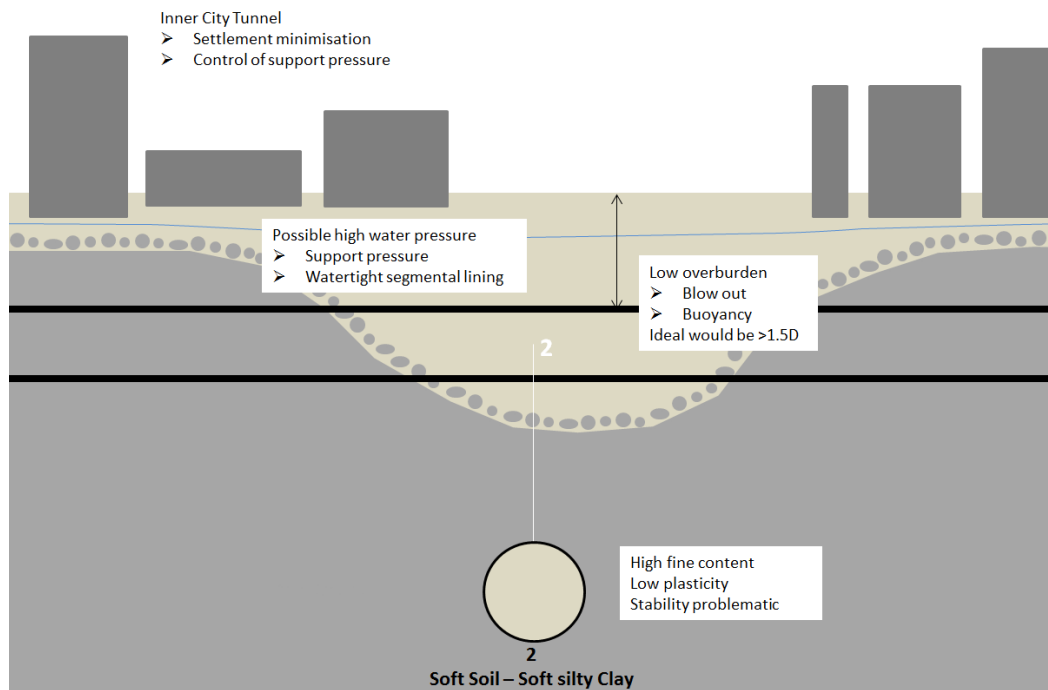

Figure 14: Challenges identified in the soft soil sections

TBM technology for soft soils

Today, two TBM alternatives using the principle of positive face support allowing to control the settlement process are on the market:

- Slurry pressured shield TBM (Hydroshield) and
- Earth Pressure Balanced (EPB) shield TBM.

The general principle of the positive face support is that the tunnel face is supported by a pressurized slurry (Hydroshield) or by a conditioned muck (EPB). The difference between these two are the density and the properties of the pressurized support medium. The different support mediums also influence the muck removal systems and a possible volume loss (inevitable with EPB shield TBM).

The table below summarizes the main characteristics of both TBM technologies.

	Hydroshield	EPB shield
Support medium	Slurry (Bentonite)	Conditioned muck material
Spoil removal system	Slurry circuit (from excavation chamber to separation plant, normally installed on the surface)	Screw conveyor and conveyor belt to the surface
Control of support pressure	Air bubble (Hydroshield) Pumping flow (slurry shield, only used in Asia)	Volume flow
Special characteristics	Submerged wall, Separation plant, Stone crusher	Conditioning of the ground

The technical application range of the above mentioned technologies can generally be described using the following figure.

Hydroshield technology is mainly used for permeable soils such as sand and gravels and with groundwater pressure up to 12-15 bar.

Earth pressure balanced TBM are well adapted for cohesive and plastic ground with limited water pressure (max. ~3,6 bar).

In practice, many other factors influence the choice of the finally selected excavation method for soft soil technology:

- ⇒ the grain size distribution (see figure below)
- ⇒ the necessity to accurately control settlements,
- ⇒ the presence of high water pressure,
- ⇒ the presence of boulders,
- ⇒ the presence of mixed face conditions,
- ⇒ the knowledge of a specific contractor
- ⇒ etc..

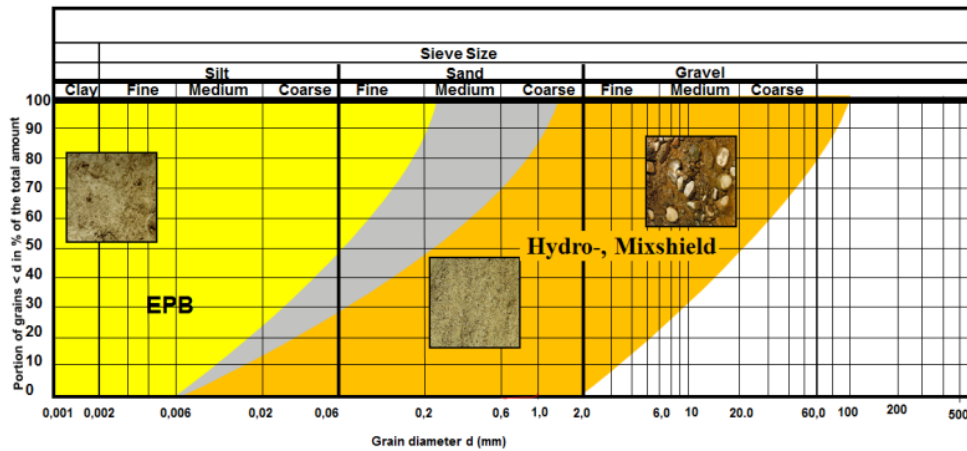

Figure 15: Theoretical application range of the soft soil TBMs

Hydroshield

Hydroshield TBMs use a slurry suspension (bentonite) for the support of the tunnel face and as carrier fluid for excavated material. Clay minerals of the suspension penetrates into the face and seal pores forming an impermeable mud cake (see picture below). The pressure of the suspension allows to balancing the water and earth pressure of the surrounding ground. This technology is widely used for bore piles and diaphragm walls.



Figure 16: Impermeable filter cake

A characteristic design feature of a Hydro shield is the submerged wall with a gate at the bottom, dividing the pressurized front section of the shield into two chambers. A compressed air bubble controls the face and support the pressure.

In this way, the support pressure of the face is completely independent from the volume flow of the suspension and only based on the air pressure control. This allows to control very precisely the support pressure and to react quickly to any

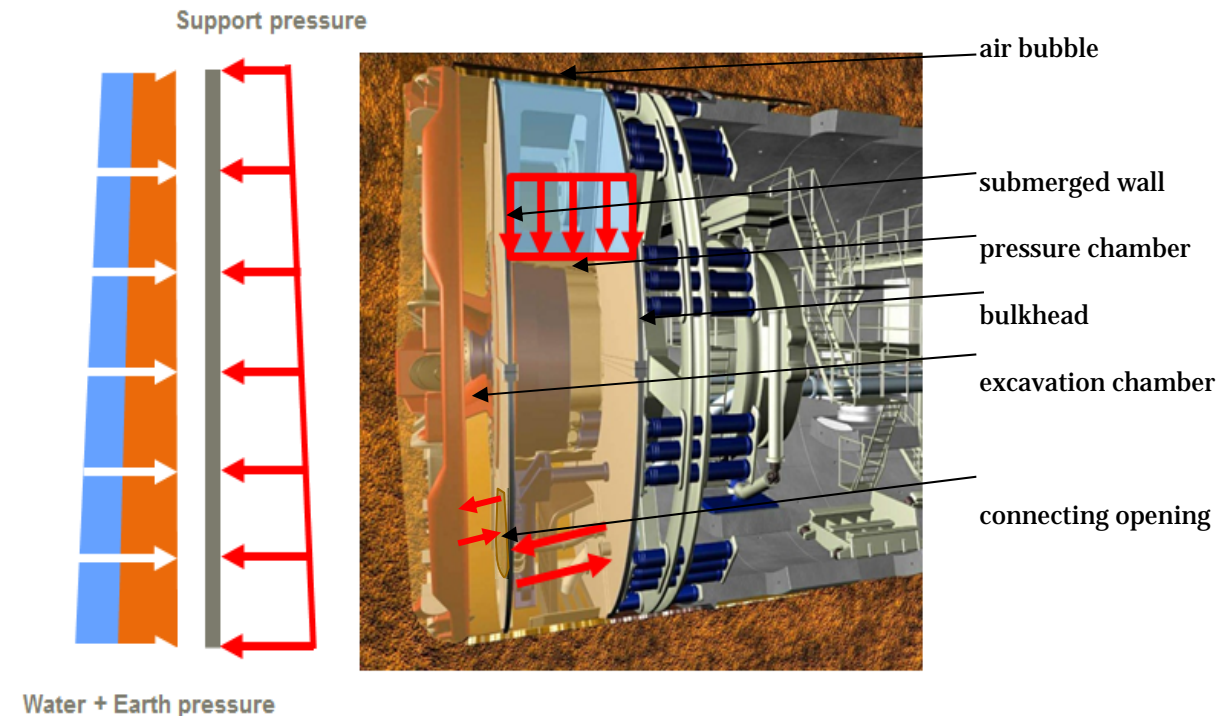

pressure fluctuation by acting on the air cushion chamber.

Figure 17: Support pressure regulation thanks to an air bubble

The opening in the submerged wall is equipped with a gate to enable an isolation of the pressure chamber from the excavation chamber. By closing the gate, pressure in excavation chamber remains constant (controlled by a remote pressurized bentonite tank air bubble system, usually installed on the TBM back-up system). The pressure in the pressure chamber can be reduced to atmospheric conditions for emergency interventions or maintenance works.

Integral to the Slurry shield concept is the ability to lower easily and quickly the slurry level in the excavation chamber for face access and cutter head maintenance.

One of the most challenging points for contractors using Hydroshields is the suspension circulation and the separation of the excavated material from the bentonite suspension in a separation plant usually installed on the surface.

A Hydroschild with a diameter of 10 m has a circulation volume up to 800 m³/h of which 10% are excavated soil and 90% circulating suspension. In the separation plant the process of separating the excavated soil from the carrier fluid requires several steps to handle each grain size.

The first steps are the coarse particle separation and fine particle separation with sieves. Silt and clay separation implies the use of hydro-cyclones, centrifuges, and filter press (with or without flocculent).

The higher the fine content in the excavated material, the more expensive the process of separation. As clay particles are approximately of the same size than those of bentonite the clay quota of the soil not only defines the extent of separation but also the advance rate.

Both the Skymetro in Zürich and the new metro of Berlin were (/are) built using Hydroschild TBMs. Those two projects are detailed in the “reference” section.

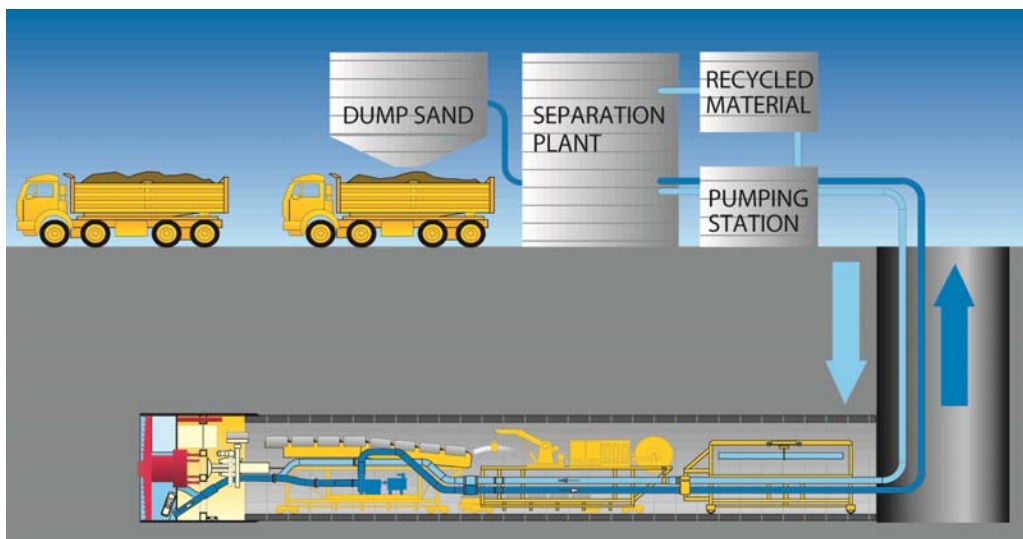

Figure 18: Separation plant necessary for Hydroschild TBMs

In middle and northern Europe, most of the main contractors are familiar with the technology of separation plants, while south European contractors often reject the use of Hydroschild technology by trying to extend the application range of EPBs using different types additives with more or less success.

Earth Pressure Balance Shield (EPB)

In an EPB shield TBM, the conditioned material excavated by the cutting wheel serves as a support medium. “Conditioned” means that water and additives are added to the excavated soil to generate a degree of plasticity which transforms the soil into a pasty mass not too stiff to block/clog the entrance of the screw conveyor

and not too fluid to flow through it like a liquid. EPB system only works properly with a complete pressure reduction from the excavation chamber (screw intake) to the material discharge on the conveyor belt (screw outlet).

The screw conveyor allows controlling the volume of the excavated and conditioned muck.

Running an EPB shield TBM successfully implies synchronizing cutting wheel rotation speed, advance speed of the shield and rotation speed of the screw conveyer. If done properly it is possible to establish a controlled volume balance resulting in a constant face support pressure. This ensures that ground settlements at the surface are kept as small as possible (EPB system always entails a volume loss of min. 0,3% in optimal soil conditions).

The regulation of the support pressures by the muck flow through the screw conveyor, becomes more and more difficult for larger tunnel diameters where higher volume flows are required for a sufficient advance rate of the EPB shield TBM.

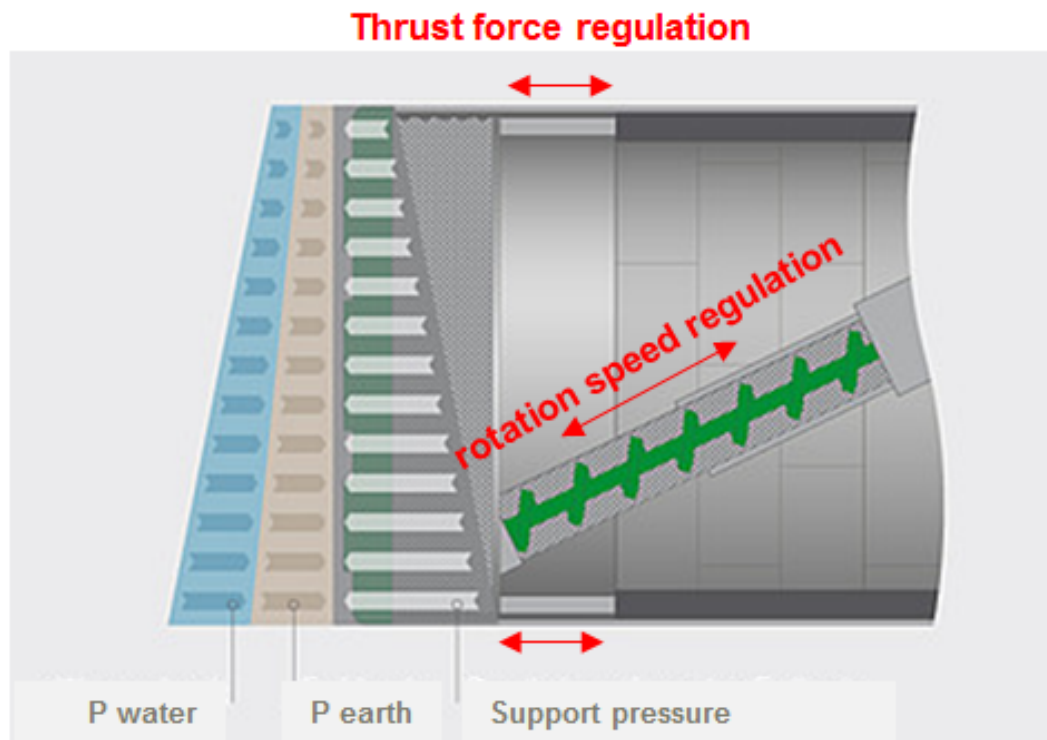

Figure 19: Support pressure regulation by the flow

If the soil doesn't have the optimal characteristics for a simple conditioning with water, additional conditioning materials like foam, polymers, fillers, etc. will be injected in order to reach the required consistency in a specific ground.



Figure 20: Ideal consistency of the conditioned material using EPB

Besides the consistency of the conditioned soil fill in the excavation chamber, the excavation process depends on many factors. This includes the advance and rotation speeds of the cutting wheel, its position, the direction of rotation of the cutting wheel and the applied thrust force.

One of the big challenges in areas where settlements should be avoided is the fact, that the earth pressure values measured at the pressure bulkhead don't necessarily correspond to the actual support pressure at the tunnel face. Therefore settlements can never be completely excluded.

The Sabadell metro (in Barcelona) and the New Delhi metro projects were built using Earth Pressure Balanced TBMs. These projects are mentioned in the following reference list.

Important features for the TBM concept to cope with hard rock are

As previously mentioned in above chapters, the TBM required for the hard rock section needs:

- ⇒ A massive cutter head with hard rock cutting tools (disc cutters),
- ⇒ A shield accordingly equipped to install a watertight segmental lining.

Important features for the TBM concept to cope with soft soil are

- ⇒ A cutting wheel with an opening ratio designed for an easy material flow,
- ⇒ Cutting tools like scrapers and rippers to excavate soft soils,
- ⇒ A spoil removal system which will consist either of a slurry circuit or of a screw conveyor with conveyor belt

Transition zones

The transition zones, between the hard rock sections and the soft soil sections represent a big challenge for any tunnel construction. Indeed, in those areas, the tunnel face is located within ground units represented by very different engineering characteristics.

The tunnel face will partially consist of hard and competent rock and partially of very soft soil like silt clay. The interface itself comprises weathered rock and often a layer of boulders.

Additionally, the groundwater level between tunnel and surface, the low overburden and the necessity to minimize settlements in urban areas have to be taken into account.

The length and frequency of these transition zones varies depending which alignment finally chosen.

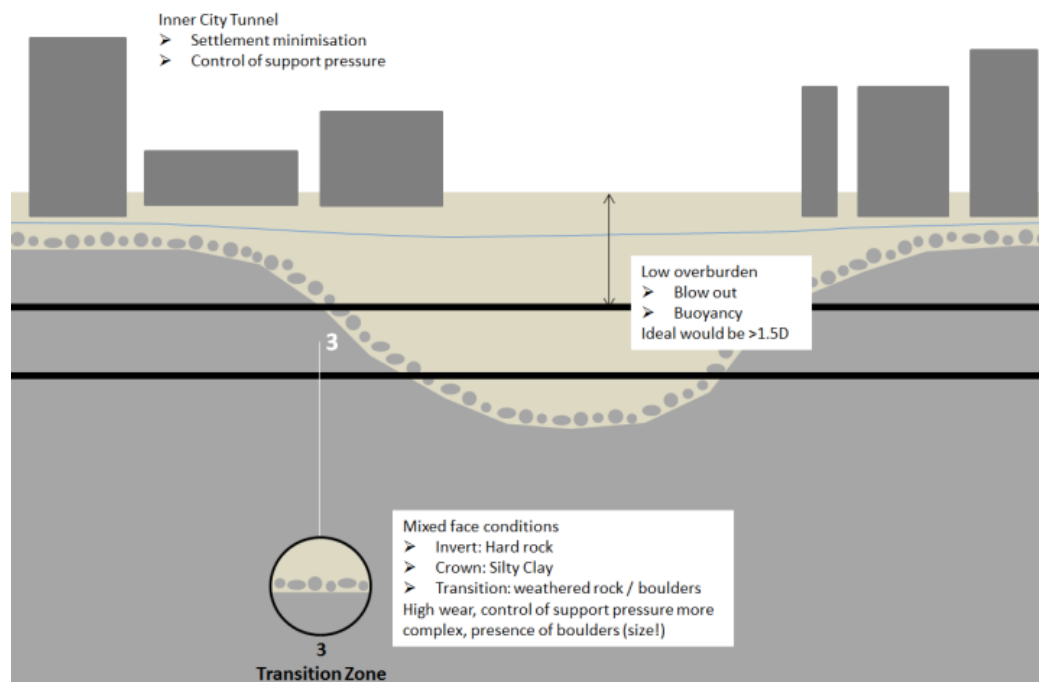

Figure 21: Challenges identified in transition zones

The potential challenges are:

- ⇒ Mixed face conditions (high wear, high stress level on the cutter head due to different loading, etc.)
- ⇒ Presence of boulders
- ⇒ Control of the confining pressure to minimize settlements (groundwater pressure, instable ground conditions)

- ⇒ In transition zones where low overburden, the risk of finding steel structures (bore-hole steel cases, etc...) are a pending task. This must be taken in to consideration and evaluated when this can be a significant and costly experience if this is not shown in the risk analysis
- ⇒ Carrying capacity of the ground in soft clay.

Mixed face conditions

In many projects with mixed face conditions (rock-soil, soil-rock, soil-soil) tunnel crews are challenged intensively. Using any of the above mentioned combination between hard rock and soft soil technologies (dual mode TBM) those zones will be very complex to go through and will require an experienced team.

The following requirements have to be combined:

- Cutter head equipped with disc cutters to cope with hard and weathered rock layers
- Scraping tools to cut moraine and silt-clay which are overlaying the rock
- TBM thrust should be kept below accepted limits to avoid possible overloading of cutters in contact with rock while simultaneously supporting the excavated face (easier to be handled by articulated cutter heads)
- Wear protection of all steel structure and tools in contact with muck due to the raising abrasiveness of hard rock chips imbedded in fluids (grinding paste)
- Accurate pressure control to keep the face pressure any moment within the calculated limits to avoid extensive settlements
- Avoid ground loss from over-excavation of granular material as more resistant material is being excavated in other parts of the face
- Minimize tunnel face accesses for intervention or maintenance reasons which require to change the face support from conditioned muck or suspension to compressed air

Presence of boulders

Boulders are handled differently by the two soft soil TBM systems. As long as the boulder remains imbedded in the soil, its size is reduced by the normal cutting process of the disc cutters. As soon as the boulder is freed from its embedding as a result to the dynamical forces of the passing disc cutters, it will start to rotate freely with the cutter head at the tunnel face.

- Using a Hydroshield TBM the groove created in the face by the circulating boulder is constantly filled up with suspension. As soon as the boulder reaches the periphery of the cutter head it will enter the excavation chamber, fall at the invert and be reduced in size by a stone crusher to fit the dimensions of the conveying pipes before to be sucked by the slurry circuit.
- Using a EPB shield the groove created in the face by the circulating boulder is filled up with conditioned soil leading to bigger volume loss and therefore increased settlements. The boulder will rotate with the cutter head until being downsized to the limit given by the grill bars of the muck entries into the excavation chamber. The muck is then transported out of the excavation chamber using the screw conveyor.

Big blocks of rock are easier to handle using a Hydroshield TBM due to the stone crusher installation (crushing the blocks to an acceptable size). The presence of slurry equipment allowing a better control of support pressure and a reduction of the friction (resulting in less wear on the steel components).

Using an EPB shield, the process is longer because the blocks of rock have to be handled by the cutter discs. The resulting pieces are harder to handle on the mucking system (through screw conveyor, discharge gate and conveyor belts). This results in a less accurate control of the support pressure. Moreover, as the friction is very high in EPB Mode, the wear on the steel structure are higher.

TBM excavation through soft clay filled “valleys”

In parties where the carrying capacity of the ground is low, there will always be a certain focus on keeping the stability of the TBM and perform the right methods to avoid settlements. The next figures shows how a TBM can be controlled even in very poor soil conditions. Thus, one can with experienced and a proven methods maintain operating in varying rock quality and soil types.

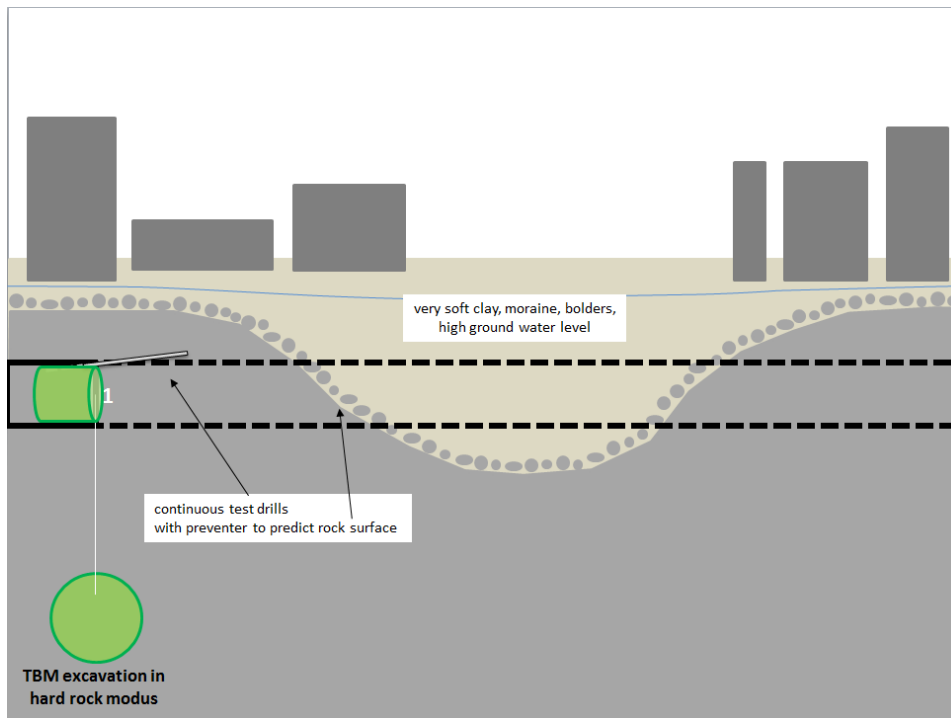

Figure 22: TBM excavation through soft clay (1)

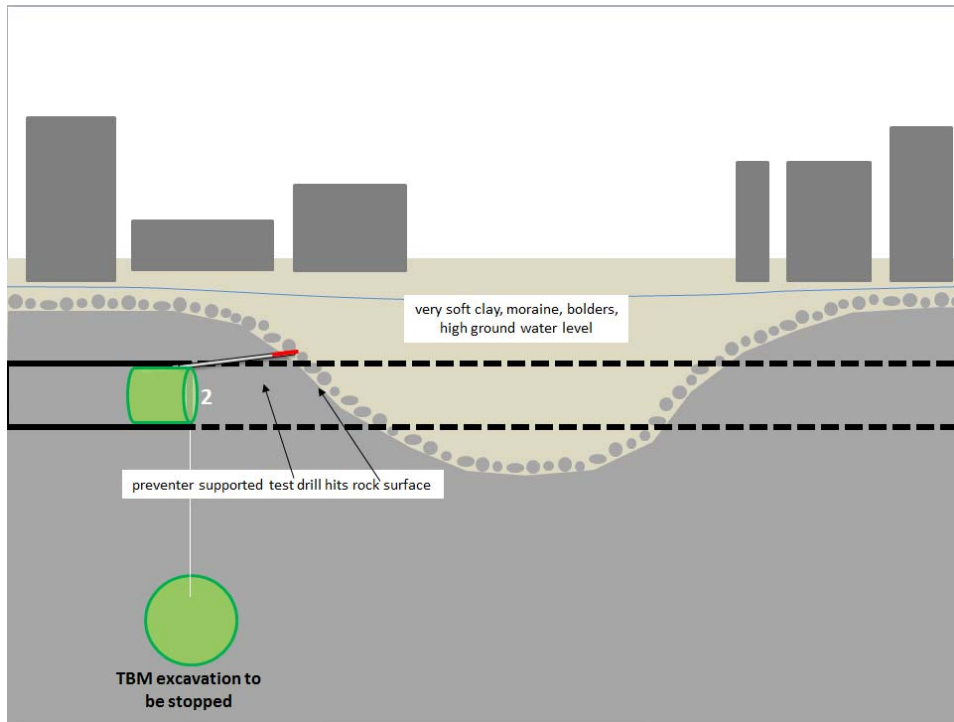

Figure 23: TBM excavation through soft clay (2)

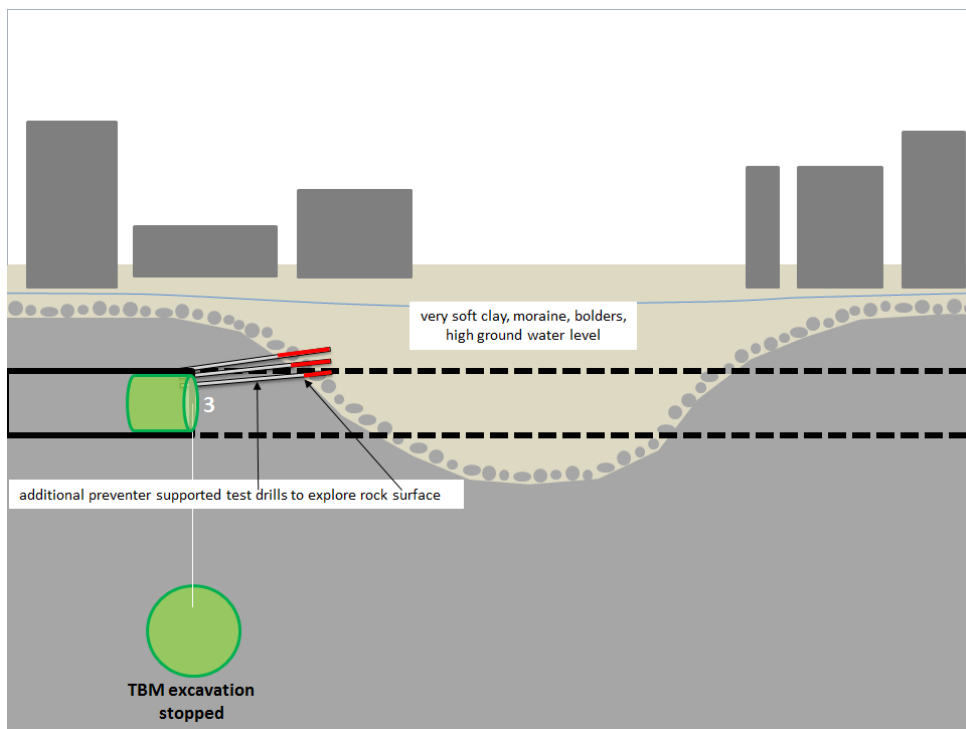

Figure 24: TBM excavation through soft clay (3)

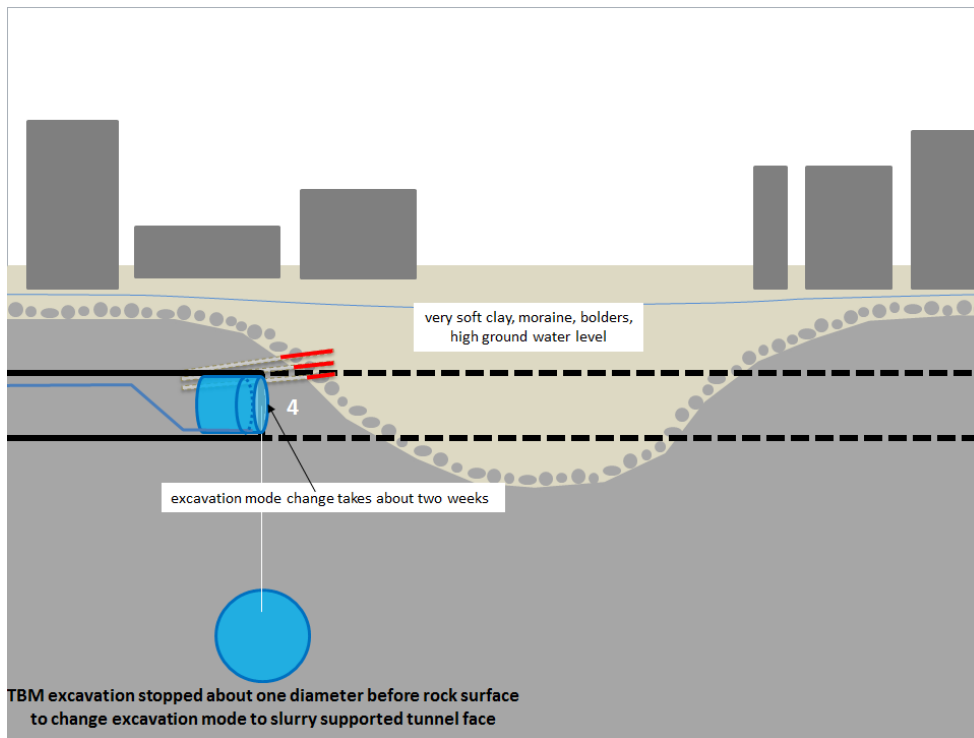

Figure 25: TBM excavation through soft clay (4)

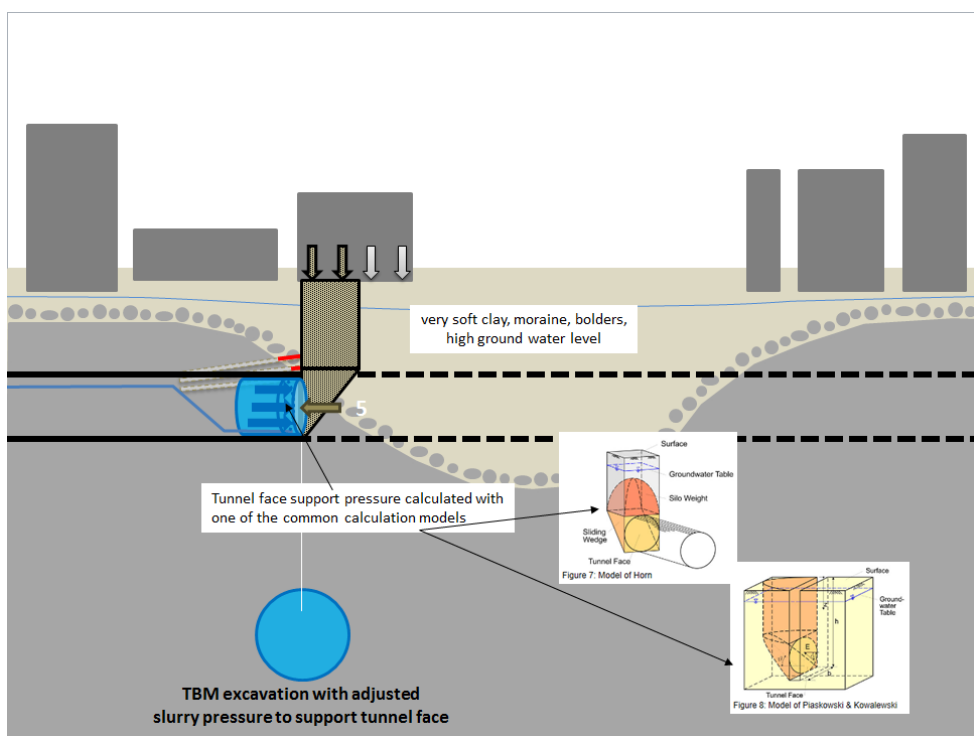

Figure 26: TBM excavation through soft clay (4)

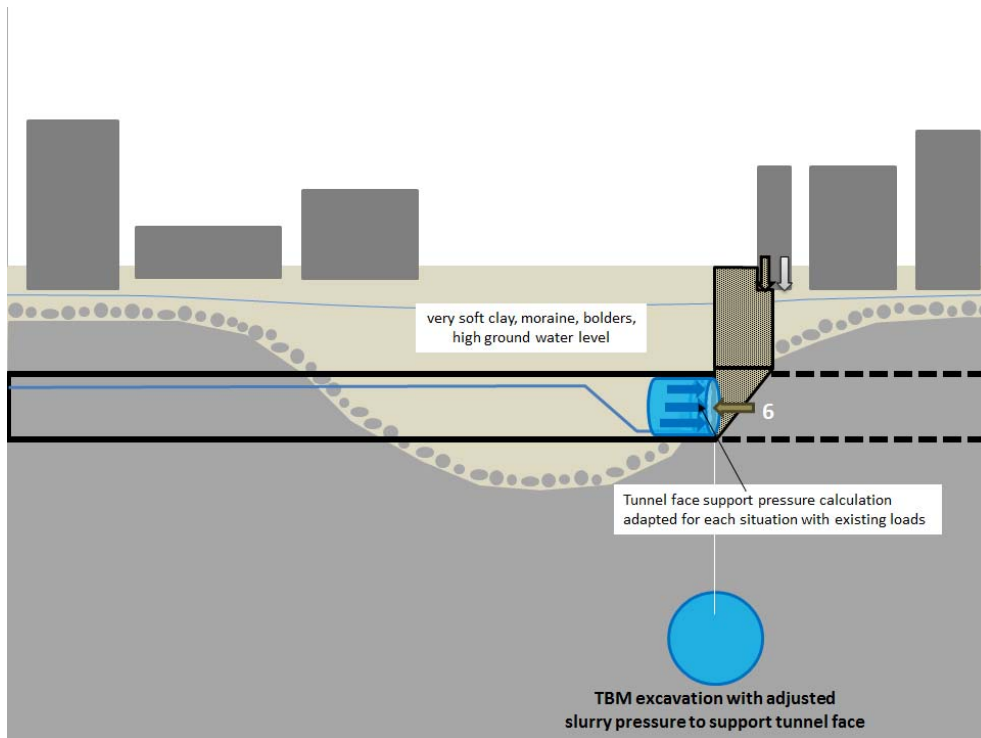

Figure 27: TBM excavation through soft clay (5)

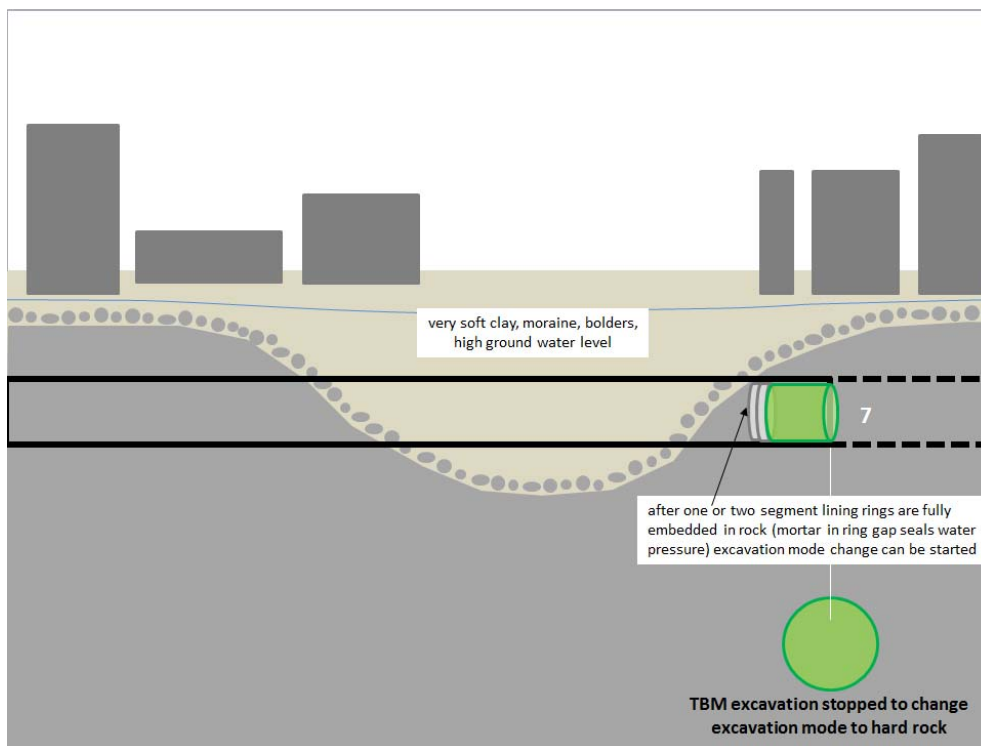

Figure 28: TBM excavation through soft clay (6)

Multi-Mode TBMs, the solution for changing geological conditions

Classic tunneling shields can reach their technical or economic limits with their specific method when they have to drive through highly variable geological conditions.

Alignments where two opposite geologies succeed to one other pose the most demanding challenges in tunnel construction. To provide a solution to changing ground conditions, TBM suppliers have recently developed a generation of Multi-mode TBMs. These allow tunneling mode conversions to adapt to the current geology within relatively short times and incurring only low costs.

As a result it is also possible to construct tunnels with extremely varying geological and hydrogeological conditions safely and cost-effectively.

Multi-mode TBMs with an open and slurry-supported mode have been used successfully in many projects. The greatest challenge when changing the tunneling mode is to deal with the different ways of removing the excavated material.

The slurry-supported shield has a slurry circuit installed in the open mode where the material is removed using a center belt conveyor with retractable muck ring.

This means that both conveying systems must be installed on the TBM, on the back-up system and in the tunnel up to the surface with such a combination. Modular and integrated TBM concept solutions are available.

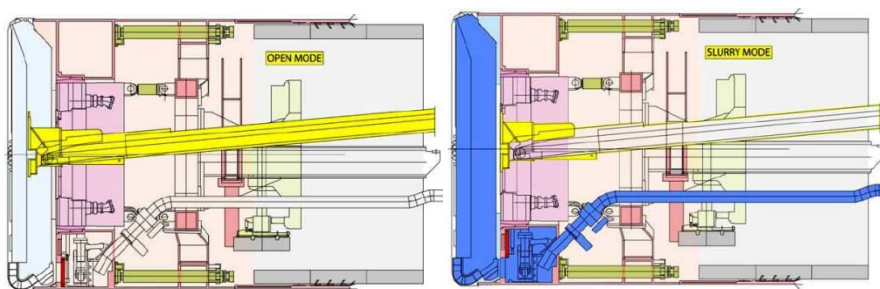

Figure 29: Example of a multi-mode TBM (change open mode / slurry mode, www.herrenknecht.com)

EPB Shields with screw conveyor in the invert section can be driven in the conventional closed EPB mode and also in the open mode with no active support of the tunnel face. In the open mode the excavation chamber and screw conveyor are only partly filled. Alternatively, a belt conveyor with a retractable muck ring can be installed in the center. This requires additional conversion measures at the cutter head, and the screw conveyor has to be partly retracted. The combination of EPB

shield and hard rock TBM can be designed with a modular basic structure and as a version with parallel screw and center belt conveyor.

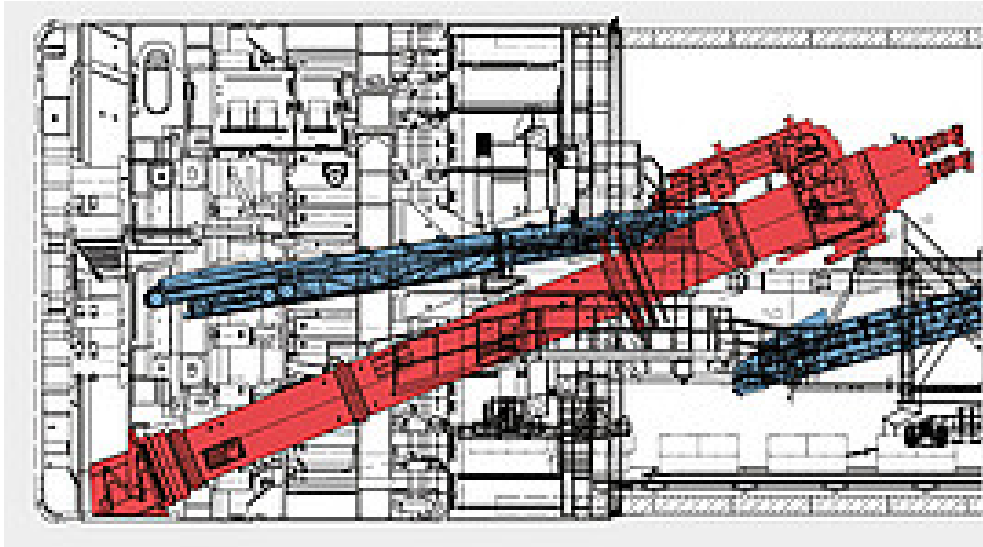

Figure 30: Example of a multi-mode TBM (change open mode / EPB mode, www.herrenknecht.com)

Comparison of a Multi-Mode Hydro shield and EPB

The table below shows the advantages and disadvantages for both soft ground tunneling systems, slurry-supported Shields and EPB Shields.

Criteria	Multi-Mode Hydrosshield	Multi-Mode EPB
Settlement control in term of face stability	Support pressure control more accurate, Distribution of face support homogeneous Possibility to react very fast	Support pressure is less accurate Fluctuation of face support pressure
Settlement control along the shield	No need to inject slurry Uniform distribution of the confining pressure in steering gap	Slurry has to be injected Non uniform distribution of the confining pressure
Settlement control behind the shield	Support and back-fill has to be precisely designed and realized	
High fines content	High separation effort Risk of clogging expected to be low due to low plasticity of clay	Better for soil with high fines content
Mixed face conditions	Better control of face support Less wear (due to bentonite)	Higher risk of instability (ground loss) More extensive wear
Boulders	Easier to handle due to suspension and stone-crusher installation	Have to be broken by cutter discs (process can be long) Harder to handle on the mucking system (screw conveyor – discharge gate – belt conveyors)
Accessibility to tunnel face	Faster emptying of excavation chamber Compressed air application	Longer preparation time to access excavation chamber Compressed air application

	easier Low temperature	more difficult Higher temperature (friction)
Mode Change	Fast Modifications are “smaller” Slurry pipes and separation required	Slow Big work to be done Problem with small tunnel diameters, disassembly of screw conveyor required, etc.

Handling clay conditions

Handling clay using a Hydro shield Mode is more complex than with a EPB. Indeed there are more risk for clogging if the clay is very plastic. The separation process when cleaning the bentonite from the spoil material can be time consuming and cost-intensive.

If the clogging risk is high, it is recommend to design the cutter head with enough openings in the center area, plan agitators (to keep the clay in motion) and use a flushing system to prevent the clay to accumulate.

Plasticity (in relation to stickiness)

The stickiness can generally be estimated using the Limit of Liquidity (LL - water content for which the soil has liquid property), the Limit of Plasticity (PL - water content for which the soil has plastic property) and the natural moisture of the soil (w - Water Content).

After calculation of the plasticity Index $IP=(LL-PL)$ and the consistency Index $IC=(LL-W)/IP$, it is possible to get an idea of the stickiness of the clay.

If the natural moisture of the clay is expected to be high, resulting in a low consistency index and the risk of clogging is relatively low. This part of the investigations is done before deciding the requirements for an TBM.

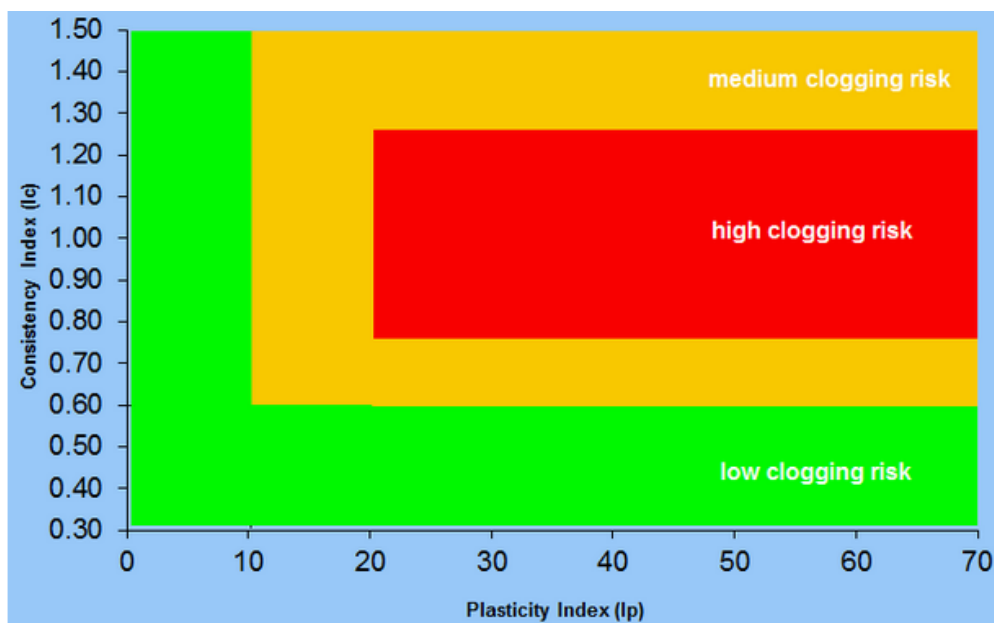

Figur 1: Clogging risk connected to the relationship between plasticity and Consistency Index

Special design features

Combined rock-soil solutions require special design features or design adaptation possibilities.

For example, the cutter head, which should be strong enough to absorb the loads resulting from the cutting process, should also be open enough to allow an easy material flow. An often used solution is to equip the cutter head with 19" housings and 19" disc cutters for the hard rock sections and to replace them alternatively by 17" disc cutters and/or by ripper tools in the soft soil sections where more openings are required.

Some components will have to be special assembled or disassembled, depending on the excavation modus. For example:

- ⇒ Muck ring
- ⇒ Conveyor belt
- ⇒ Stone crusher
- ⇒ Slurry circuit
- ⇒ Air lock,
- ⇒ Etc.

If considering a "multi-mode" Hydro shield TBM, a separation plant will have to be installed for the corresponding modus. In order to minimize the circuit length and thus the costs, the separation of coarse and fine particles could be installed on the TBM back-up and transported to the surface with the belt conveyor while fines and clay fractions would be treated in a separation plant on the surface.

Site access and rig area

In urban areas, finding a suitable rig area can be a challenge, where access to adequate space is a constraint. From the project's point of view, it is very important to start the process to prepare the legal access to these areas in an early phase of the project. Normally there are many important factors to consider compared to rig sites placed in a remote area.

To move a TBM (from where it is produced according to project requirements) to a place where it can be assembled and ready for use, is a tedious process that must be planned in detail.

The size of a TBM can vary. ie project requirements and parameters (diameter of the tunnel, geological occurrence, environmental parameters, +++) governs the choice of machine type.

Compared to the conventional tunneling operation (drill & blast), the startup of a TBM-drive, demands more rig site space.

A TBM of larger size, i.e. larger than 8-9m in diameter, has a long backup system. This may require space/ caverns up to 250m.



Figure 31: Kralovopolsky Tunnel, Dobrovského (Czechia)



Figure 32: Installation of a hydro shield TBM for tunneling under Zurich airport (Amberg archive)



Figure 33: Rig area U5 Metro project in Berlin (Amberg archive)



Figure 34: London Crossrail (<http://www.crossrail.co.uk/>)

Environmental overview

Summary/comparison between TBM and drill & blast

- ⇒ TBM - vibrations connected to TBM drilling compared to the conventional method (drill & blast) - Blasting can create vibrations difficult to handle.
- ⇒ TBM has smaller impact on water consumption and it leads again to less waste water (process water) than drill & blast. Drill & blast method can have challenges connected to handling water containing nitrogen.
- ⇒ TBM creates noise when drilling. Measurements necessary to keep the noise level within and accordingly to Norwegian regulation (ec. T-1442). If the rig site placed in urban areas, there must be measurements implemented on the rig site to comply with the environmental guidelines.
- ⇒ Muck transport from a TBM can be executed by a conveyor belt, directly from tunnel face to transport facility or deposit.

Recycling of the muck material

Using tunnel muck as concrete aggregate and other possible products, can have economic and environmental advantages in a project.

In a practical view of the project, the muck recycling will be actual if it is economical reasonable, has the important environmental effect, and can be performed within limits of practical measurements.

In which the much is useful for recycling to the project depends on many parameters and properties of the rock mass. However, considering the rock quality in Oslo area, it may not be suited for use in concrete structures.

Conclusions and recommendations

This report focuses on the different technical solutions to implement in order to reduce or eliminate the identified risks connected to mechanized tunneling excavation methods using TBM.

The geological conditions for this project are based on real situations met in earlier tunneling projects in Oslo area.

Two main alternatives of TBMs able to guaranty an efficient hard rock excavation and a safe passage through soft soil sections below ground water level showed up to be possible:

- “Multi-mode” Hydroshield TBM
- “Multi-mode” EPB shield TBM

Considering the case of existing buildings are endangered by significant settlements, the risk of boulders in the transition zones of short soft soils sections, the “multi-mode” Hydroshield TBMs are recommended. This type of shielded TBM is best suited to the very complex geological conditions and allows the highest flexibility and the best performances in terms of face support control and settlement minimization.

Only if the soft soil section extends over a longer stretch, contains a high percentage of clay and fines and the settlements are less relevant due to the lack of protected buildings and existing infrastructure, a “multi-mode” Earth Pressure Balance TBM are recommended. A “multi-mode” Hydroshield TBM is less cost effective the higher the content of fines.

Ground conditioning makes the ground conditions fit the machine. The multi-mode machines makes it easier to do ground measurements while going through different soil and rock layers.

The final choice of the machine is anyway a compromise between the most important parameters of the project.

Risk assessments are a very important tool in making the best choice. The right choice of the TBM is important. In addition to the above, the entrepreneurs who possess extensive experience of TBM operations, reduce the risk of problems in the implementation of the project.

References

TBM Symposium, LUCIA 1994, Dec 1994, Stockholm: :Reuse of TBM-muck versus Cutter spacing. By: Ernst Büchi and Cedric Thalmann.

Main Aspects of Tunnel Muck Recycling, by: Rossana Bellopede, Fabrizio Brusco, Pierpaolo Oreste and Maurizio Pepino, Department of Land, Environment and Geotechnology Engineering, Politecnico di Torino Corso Duca Degli Abruzzi 24, Torino, Italy

Amberg Engineering project archive: ontaining experiences from different TBM tunneling projects.

The Hallandsåsen dual mode TBM, by Burger, 2009

Maschiner Tunnelbau im Schnildvortrieb, 2.Auflage, Maidl

Hard rock tunnel boring machines, Maidl

www.therobbinscompany.com

www.herrenknecht.de

<http://www.crossrail.co.uk/>

Appendix, Reference projects

Gotthard Base Tunnel – Hard rock project

Gotthard Base Tunnel – Switzerland

The new alpine railway link through the Gotthard creates an efficient rail network between northern and southern Europe. The two-tube Gotthard Base Tunnel is at the heart of the new rail connection designed for speeds of up to 250 km per hour. At 57 km in length, it will be the longest railway tunnel in the world.

Project Phases

Design: since 1990

Realization: 1999 – approx. 2016

The Challenge

The geological conditions vary from very compact hard rock layers to soft and squeezing interference zones and sections of soft ground. The tunnel's maximum overburden is 2,500 m. Rock temperatures of more than 50°C are expected at some points.

Construction is defined by labor intensive construction processes and demanding logistics.

The Solution

The entire logistics for the Sedrun site, with up to four simultaneous drill and blast headings, take place via two 800 m deep shafts. Cooling had to be installed to counteract the high temperatures inside the mountain.

For cutting through geologically difficult zones, excavation and safety concepts were developed for the drill and blast headings in the design. The tunnel boring machine must be able to react flexibly to changing rock behavior.

The concepts were confirmed during the successful implementation of the works.

Contact Person

AlpTransit Gotthard AG (ATG)

Dr. Renzo Simoni (director)



Vereina Tunnel – Hard rock project

Vereina Tunnel – Klosters Lavin, Switzerland

The Vereina tunnel, which connects Klosters in the Prättigau valley to Sagliains in the Engadin valley, is part of the Vereina line.

With 19'042 m, it is the longest narrow-gauge tunnel in the world.

Project Phases

Design: since 1981

Realization: 1991 – 1997

Project Description

The excavation of the tunnel was done from north with a tunnel boring machine which was also used to excavate the access gallery from Klosters to Selfranga, and from south by conventional drill-and-blast method. The breakthrough happened earlier and at a more northern point than expected on 26. March 1997 because the rock quality on the southern side was unexpectedly good and, thus, enabled a faster excavation.

Contact Person

Rhb, Rhaetian Railway

S. Fasciati (Director of Rhaetian Railways)

W. Atermatt (Chief Engineer of Rhaetian Railways)



Follobanen Oslo-Ski – Hard rock project

Follobanen Oslo-Ski – Oslo, Norway

The project is currently the largest transport project in Norway and includes the country`s longest railway tunnel (20 km). Combined with the existing Østfoldbanen, four tracks to the capital will represent more trains and faster trains on schedule.

Project Phases

Design: since 2001
Realization: 2014 - 2020

Project Description

The project consists of a new high speed railway line between Oslo Central Station and Ski. It includes the longest railway tunnel in Norway with two single track tunnels, ~20 km each. The two parallel single track tunnels will be built through Precambrian gneisses with intrusive Amphibolite dykes and rhomb porphyry intrusion using four double shield TBMs and a watertight segmental lining. High ground water level and hence water pressure onto the inner lining up to 16 bar.

The maximal overburden is 170 m.

One additional challenge will be the passage under existing traffic and sewage tunnels.

Contact Person

Jernbaneverket, Stenersgaten 1D, Oslo, Norway
Contact Person: Thor Stenersen



Hallandsåsen tunnel – Hard rock project

Hallandsåsen Tunnel – Förslöv, Sweden (www.herrenknecht.de)

The two-tube Hallandsås Tunnel for the upgrade of the rail link between Göteborg and Malmö along the Swedish west coast is one of the most challenging tunnel projects worldwide. Extremely hard as well as extremely abrasive rock is encountered along the tunnel route interchanging with sections of soft and mixed [tunnel face](#) conditions. Additionally, the groundwater puts a pressure of up to 10 bar on the tunnel. Herrenknecht designed and delivered the High-tech machine that can operate in closed slurry mode as well as in open hard rock mode. As part of comprehensive test series, the sealing system of the machine was designed to withstand a groundwater pressure of up to 13 bar. Drilling and injection equipment installed on the machine make sure that the flow of water can be controlled by grout injections.

After 5,480 meters of hard work in the first tunnel, the miners celebrated breakthrough in August 2010. After extensive revisions of the machine, the jobsite crews started excavating the second tunnel in February 2011 bringing this milestone segment ring by segment ring closer to successful completion. On September 4, 2013 the time has come: The final breakthrough after eight years of unyielding tunnelling is a grand triumph for all those involved in the project. It is the proof that with an unshakable will of clients, powerful construction companies and innovative tunnelling technology even the hardest challenges in tunnel construction can be mastered.

The railway link along the Swedish west coast from Malmö to Göteborg is one of the most important connections in Sweden. The two-tube Hallandsås Tunnel with a total length of 8.7 kilometers will enhance the capacities. First attempts to build a tunnel were aborted due to the high water pressure in the strongly fissured rock. The environmental regulations that had been passed afterwards applied for the mechanized tunnelling as well and regulated for example the amount of groundwater that was allowed to drain exactly by the liter.



Geology: heterogeneous ground and rock (gneiss, amphibolite, diabase)

Tunnel length: 10'925 m

Machine Type and diameter: Multi-mode Hydroshield of 10.53 m diameter

Lining method: segmental lining

Berlin Metro U5 – Soft soil project

Berlin Metro U5 – Berlin, Germany

In August 2009, a new section of the underground line U5 was opened between Berlin Central Station and the Brandenburg Gate.

Since March 2010, planning has progressed on completing the missing link to the existing underground line U5, the so-called “Chancellor Line” running from Alexanderplatz to the existing station at Brandenburg Gate.

Project Phases

Schematic and tender design 2010 – 2011
Support of contract award 2011
Detailed design 2012 – 2016

Project Description

The project includes the construction of three new stations with maximum pit depths of 22 m and a 1.65 km-long twin tube tunnel in the historical center of Berlin. The metro line is to be built from the Berliner Rathaus and will cross below the prestigious Humboldtforum building (in construction) before to cross below the Spree river and canal under very low overburden.

The two parallel tunnel tubes are being excavated using a Hydroschild Machine. The TBM has an diameter of 6.40 m with 35 cm-thick segmental lining, resulting in an inner tunnel diameter of 5.70 m.

The geology consists of over-consolidated sands and gravels. The tunnels will be built below groundwater table.

Over its whole course, the TBM will run under the Spree river and canal as well as under an important number of building and existing structures. The crossing below the river and the canal will require ballasting as a result to the very low overburden (6 m).

The construction of the new stations “Berliner Rathaus”, “Museumsinsel“ and “Unter den Linden“ will be realized utilizing a diaphragm wall with a maximum length of approx. 35 m. The platform hall at “Museumsinsel“ is located under the Spree Canal and will be conventionally excavated under the protection of a 100 m long section of frozen ground. The station “Unter den Linden“ is to be constructed at a crossing with the existing underground line U6.

Contact Person

Berliner Verkehrsbetriebe (BVG),
Mr. Dipl.-Geol. J. Seegers

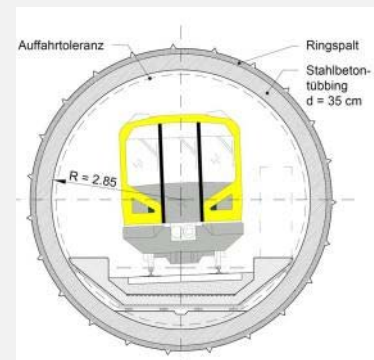

Zurich Airport Sky metro – Soft soil project

Skymetro - Zurich, Switzerland

The volume of traffic at Zurich Airport has risen sharply in the last few years. To keep up with this increase, the airport is modified and extended. At the core of this extension is the midfield terminal, with 27 extra gates between the two runways. Passengers travel from the existing airport to the new terminal in the “Skymetro” a metro-like system. Amberg Engineering is responsible for design and construction supervision.

Project Phases

Design: from 1996

Construction: 1999 – 2002

The Challenge

The two tunnels are completely underneath the groundwater table in predominantly silty, sandy lake deposits.

The tunnel passes below the existing Terminal A and a runway, which were continuously in operation during construction. The overburden is very low – only 1.5 m under Terminal A and 9 m under the main runway. Therefore, for safety reasons, particular attention has to be paid to keeping the settlement very limited.

The Solution

A hydro-shield machine was used for the tunnel excavation. The single-shell permanent lining consists of pre-cast concrete segments. The entire tunnelling is monitored by an automated surveying system which would send warnings and emergency messages to the runway operators.

The skymetro is in operation since 2003 after a tunnelling drive which did not disturb airport operation.

Contact Person

Flughafen Zürich AG, Mr M. Pfister



Metro Sabadell – Soft soil project

Sabadell – Barcelona, Spain

The extension of the FGC metro line 2 (FGC: Ferrocarrils de la Generalitat de Catalunya) in direction of Sabadell North was planned as underground structure with an overall length of more than 5 km, inclusive of a 320 m-long service tunnel, a 360 m-long rail yard and 5 metro stations.

Commissioning took place in 2012 after three years of work.

Project Phases

Execution of works: 2008 – 2011

Commissioning: 2012

Description of the Project

The project comprises the construction of a new metro line in a densely built environment. This metro line connects the city of Sabadell to Barcelona existing metro network. The overall length of the extension of the FGC line is of approx. 5 km (underground).

The geology is mainly composed of the following four ground formations:

- Gravely-sandy Quaternary (aquifer)
- Silty-clayey Quaternary (cohesive soils)
- Gravely sandy Miocene (aquifer)
- Silty-clayey Miocene (cohesive soils)

The single-track tunnels have been excavated using an earth pressure balanced TBM. 25 cm watertight segmental lining was installed to ensure the stability of the tunnel walls and to prevent water inflow. The resulting tunnel inner diameter is 6.00 m.

At the end of the extension section, there is a longer cut-and-cover section where the two single tracks tunnels converge in a twin track tunnel tube. The rail yard near the terminus station is excavated from an access tunnel by cut-and-cover method.

Contact Person

Gestión de infraestructura S.A (GISA),

Mr Sergio Gutiérrez

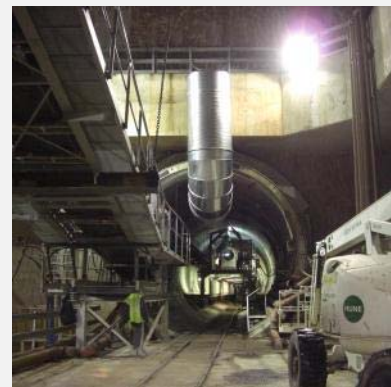

Metro Delhi – Soft soil project

Delhi has been suffering from a significant increase in traffic for years. An initial metro line for the eastwest axis has already been implemented. A second line should ensure connection to the south. A contractor awarded Amberg Engineering the design and support for construction work for the tunnels around the “Khan Market” and “Jawaharlal Nehru Stadium” stations.

Project Phases

Design: Start in 2007

Construction: 2007-2009

The Challenge

The two tube tunnel passes under densely populated urban areas, including the locations of some listed buildings. Along its entire length, the tunnel passes through partially water-saturated soft ground, composed of clays and marls, sometimes interspersed with single boulders.

The Solution

The entire tunnel section is driven with an earth pressure balance shield. The tunnels, with an inside diameter of 5.7 m, are clad in pre-cast concrete segmental lining. In the process, Amberg Engineering optimized the segmental lining for the contractor.

Tunnel connections were constructed conventionally using various construction support measures. The construction procedure for the emergency exits was investigated in detail. Instead of using a mined solution, shafts were sunk from the surface.

We have developed a monitoring concept, which provides dense measurement coverage with intensive monitoring programs.

Contact Person

Italian Thai Development Public Company Ltd.

Mr Chundee Mookhun



Grauholztunnel – Multi mode TBM

Grauholztunnel – Bern, Switzerland (www.herrenknecht.de)

Herrenknecht engineers created a pioneering hightech piece of engineering for the Grauholz Tunnel. For the first time, a Herrenknecht tunnel boring machine was design for the conversion from slurry discharge to belt discharge. The unbeatable advantage: different geological formations on a tunnel route can be excavated with a single machine.

The S-50 was designed to operate in slurry mode with active and precise support of the tunnel face in soft ground with groundwater pressure as well as the excavation as an open hard-rock machine with belt discharge. In hard rock, the machine achieved performances up to 29 meters per day and in closed mode up to eleven meters per day. The conversion from one mode to the other could be realized within one day. Another novelty in Swiss tunnel construction was the use of single-shell lining segments.

The Grauholz Tunnel is part of the high speed rail connection from Bern via Olten to Zurich and, thus, is like the Murgenthal Tunnel (Herrenknecht Single Shield TBM) a center piece of the "Bahn 2000" project with which the Swiss were making their rail network future-proof.



Geology: heterogeneous ground and rock (sand, gravel, molasses)

Tunnel length: 5'500 m

Machine Type and diameter: Multi-mode Hydroschild of 11.60 m diameter

Lining method: segmental lining

Weinbergtunnel – Multi mode TBM

Weinbergtunnel – Zürich, Switzerland (www.herrenknecht.de)

Zurich has been redefining itself continually since the end of the 20th century – as an open, lively metropolis with an international flair and offering a high quality of life. One of the most important infrastructure projects in Zurich is currently the so-called "Durchmesserlinie" (Diameter Line) – a dual-track railway connection through the city which also involved the construction of a very complex tunnel, an underground through station and the development of a new quarter around the central railway station.

This major "Durchmesserlinie" project will transform Zurich's terminal station into a through station. The convertible S-451 Mixshield known as "Belena" with a diameter of 11,240mm was employed on the Weinberg Tunnel section. This railway tunnel with two tracks in a single tunnel represented a particular challenge on account of its geology which features both molasse and unconsolidated rock.

A well-attuned team of experienced miners was working on the high-tech machine: In the hard-rock section segment rings (5+1 segments) were installed in less than 15 minutes and several hyperbaric interventions were carried out successfully along the groundwater-bearing section. After the conversion from open to closed mode, the shield machine bored its way toward Zurich Central Station beneath the Limmat River along the last 280 meters of the tunnel route. On November 22, 2010, the miners celebrated the successful breakthrough of the [TBM](#) in the [target](#) shaft.



Geology: heterogeneous ground and rock (soft ground and molasses)

Tunnel length: 4'416 m

Machine Type and diameter: Multi-mode Hydroschild of 11.24 m diameter

Lining method: segmental lining

Zimmerbergtunnel – Multi mode TBM

Zimmerbergtunnel – Thalwil, Switzerland (www.herrenknecht.de)

The Zimmerberg Base Tunnel between Zurich and Thalwil forms a centerpiece of the large-scale rail project "Bahn 2000" that, in combination with the NEAT Project (the new rail link through the Alps), will significantly enhance the efficiency of the Swiss railway system. The mechanized [tunnelling](#) faced challenges like an extremely wide range of geological conditions and localized little [overburden](#) under the Zurich urban area. At about a third of the length of the route, two TBMs started in opposite directions from two adjacent launch shafts.

The Herrenknecht Mixshield S-140 provided the solution for tackling the varying geological conditions encountered on the route to Zurich: it could be converted inside the tunnel from dry to wet mucking thereby enabling tunnelling in both intact rock as well as in aquiferous soft ground. Tunnelling had to be carried out under residential buildings and business premises in Zurich, but thanks to the use of pipe arches, injections and sensor systems the project was concluded safely in May 2001 with a minimum of [settlement](#).

40.8 meters of world record tunnelling in one day performed the Single Shield [TBM](#) S-139 by Herrenknecht on its way to Thalwil through the sandstone of the Upper Freshwater Molasse. The Hard Rock TBM crossed the finish line in early December 1999 after only 15 months of tunnelling.



Geology: heterogeneous ground and rock (soft ground and molasses)

Tunnel length: 8'190 m

Machine Type and diameter: Multi-mode Hydroschild of 12.33 m diameter

Lining method: segmental lining

Finnetunnel – Multi mode TBM

Finnetunnel – Herrengosserstedt, Germany (www.herrenknecht.de)

The almost seven-kilometer-long twin-bore Finne Tunnel is the largest tunnel structure along the Erfurt and Halle/Leipzig section. To master the challenging geological conditions, Herrenknecht designed two high-tech machines that successfully completed [tunnelling](#) four and seven months ahead of schedule.

The first 1,500 tunnel meters of each tube were particularly challenging, since they were characterized by the Finne Fault consisting of hard and extremely weathered rock and soft ground formations. Since the groundwater table was present up to 50 meters above the crown mechanized tunnelling was only possible in closed mode using a Mixshield. The remaining approx. 5.5 kilometers were characterized by considerably easier ground conditions. Herrenknecht engineers solved this problem with two Mixshields that could be converted to open mode after completion of the first 1.5 kilometers. Jobsite workflows and [TBM](#) schedules were coordinated in a way to allow the disassembly of all slurry components of the first TBM for a reuse on the second TBM that was launched at a later point of time.

Breakthrough along the northern tunnel section was scheduled for September 30, 2009. The first Mixshield reached its target after 16 months and 6.8 kilometers of tunnelling - four months ahead of schedule - with best weekly performances of 202 meters. Along the southern section the second TBM was even faster. Breakthrough occurred on February 10, 2010 - seven months ahead of schedule.



Geology: Heterogeneous ground and rock (sandstone, mudstone)

Tunnel length: 13'614 m

Machine Type and diameter: 2 Multi-mode Hydrosields of 10.82 m diameter

Lining method: segmental lining